

ENCOFRADO ALCANTARILLA TIPO LOSA
Esc. 1:50

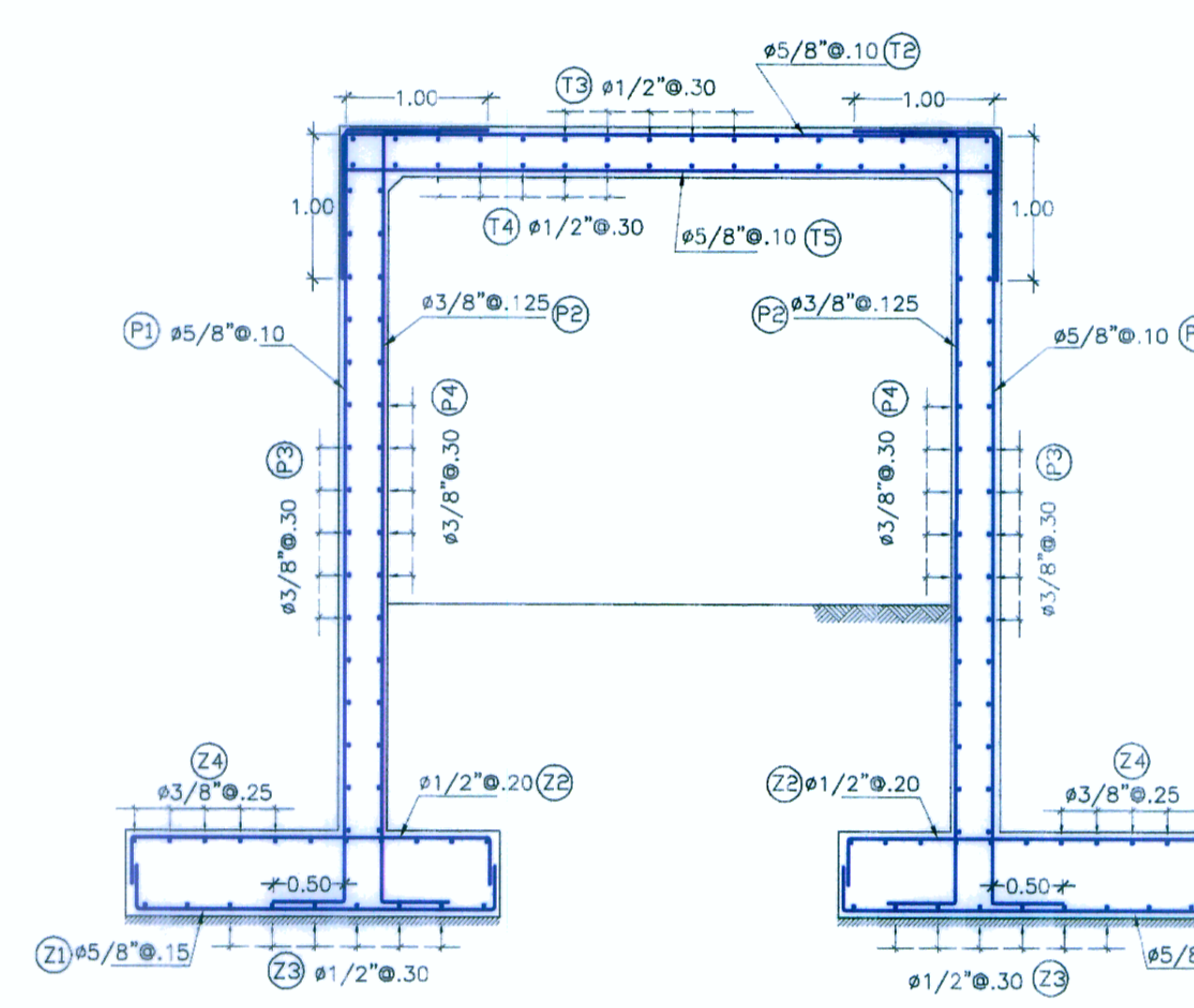

ARMADURA CORTE 4-4
Esc. 1:50

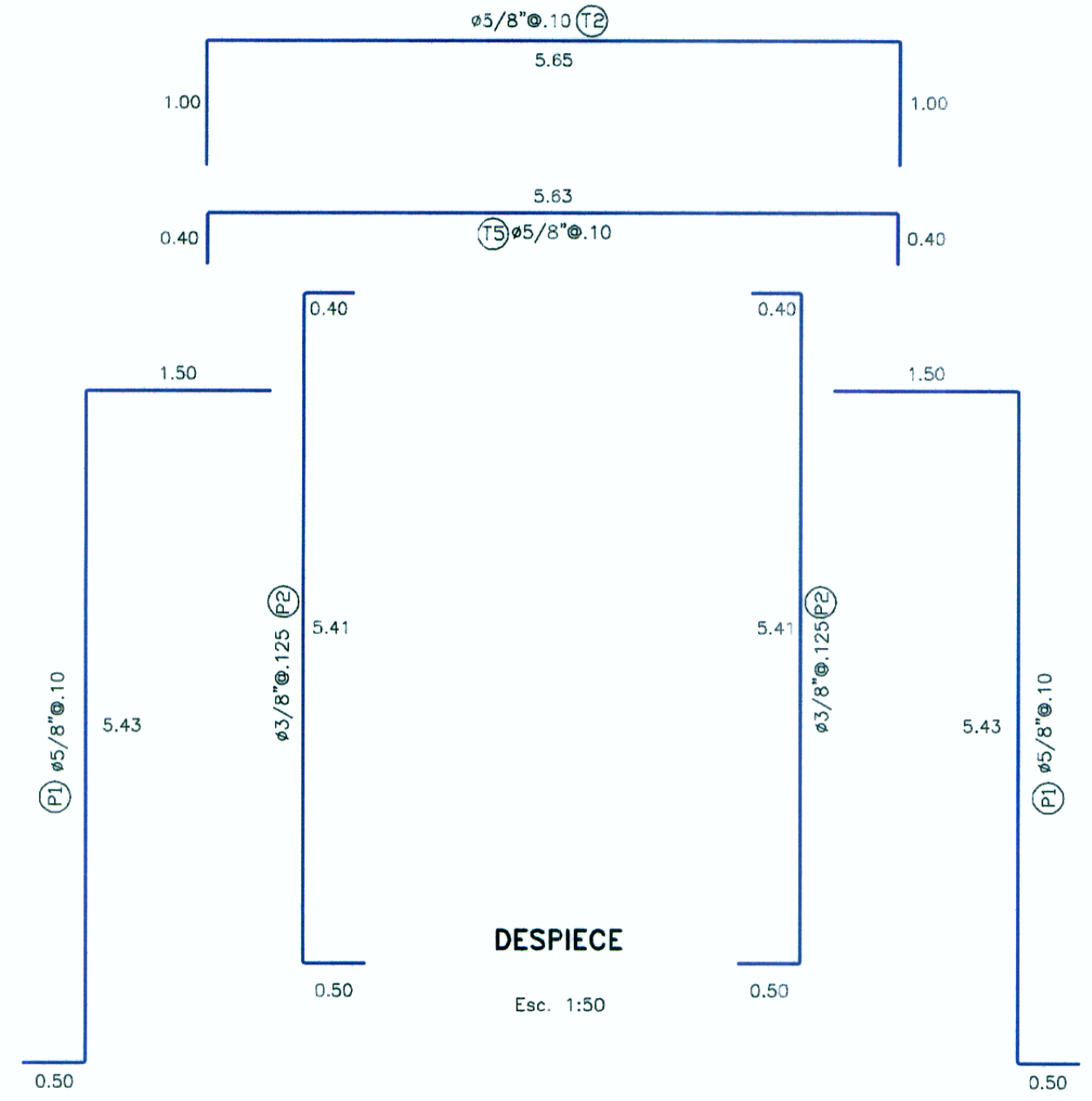

DESPIECE
Esc. 1:50

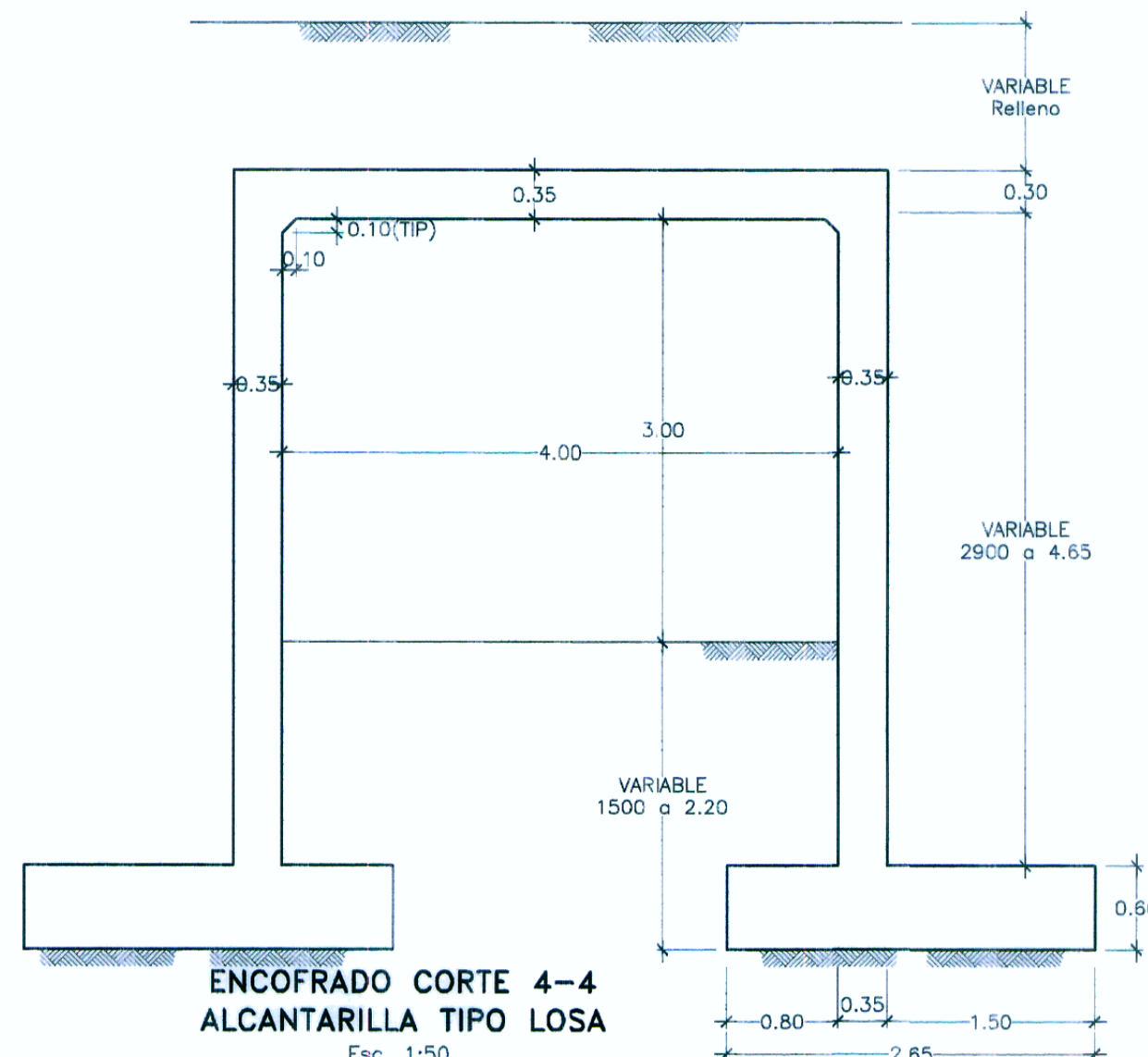

ENCOFRADO CORTE 4-4 ALCANTARILLA TIPO LOSA
Esc. 1:50

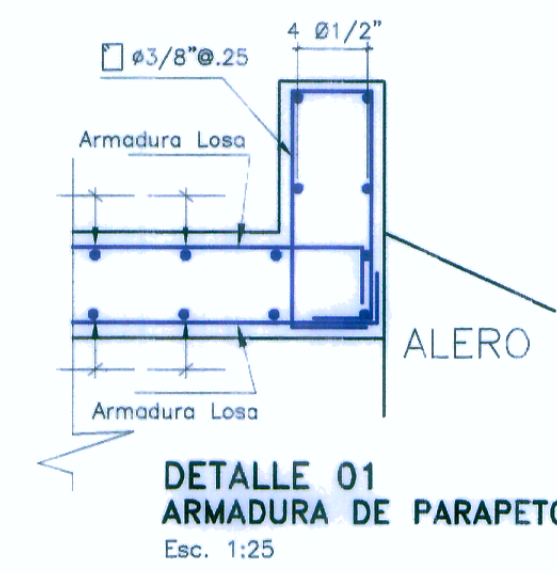

DETALLE 01 ARMADURA DE PARAPETO
Esc. 1:25

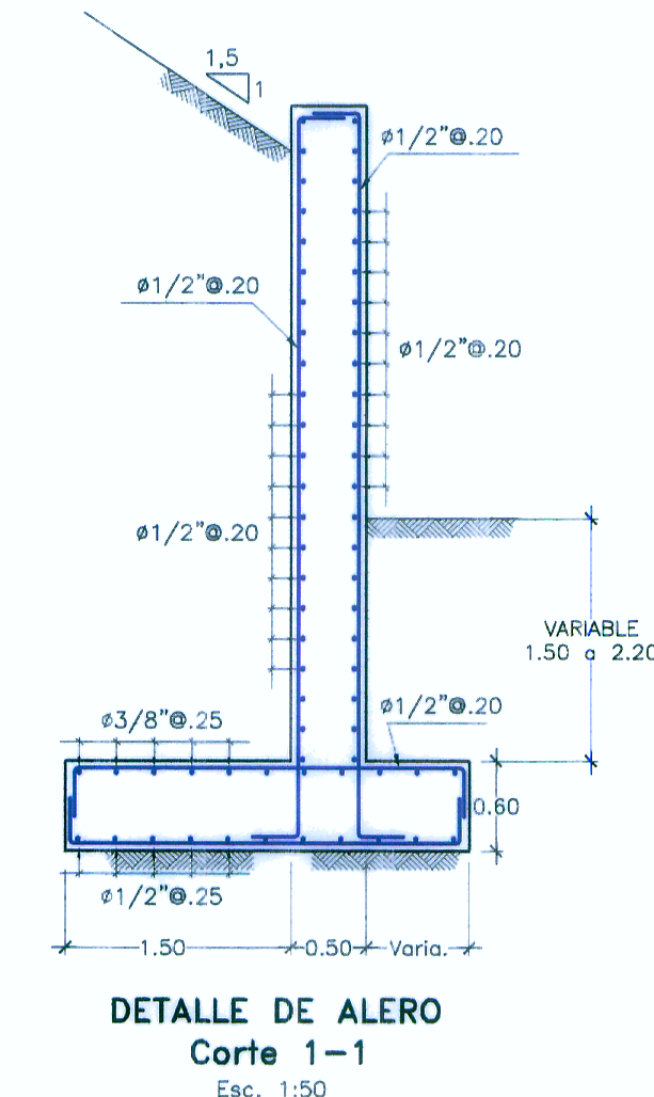

DETALLE DE ALERO CORTE 1-1
Esc. 1:50

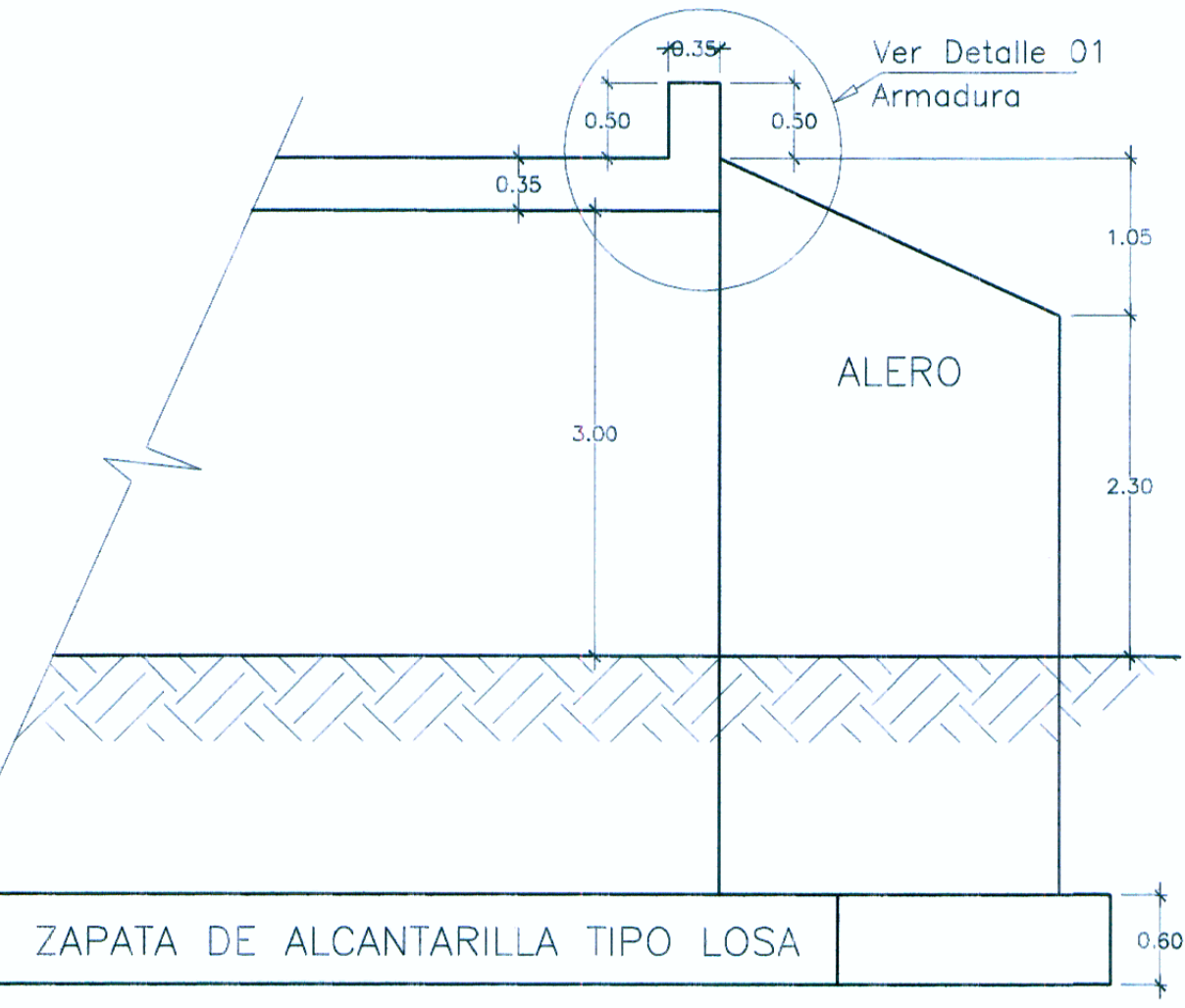

CORTE 2-2 ALCANTARILLA TIPO LOSA
Esc. 1:50

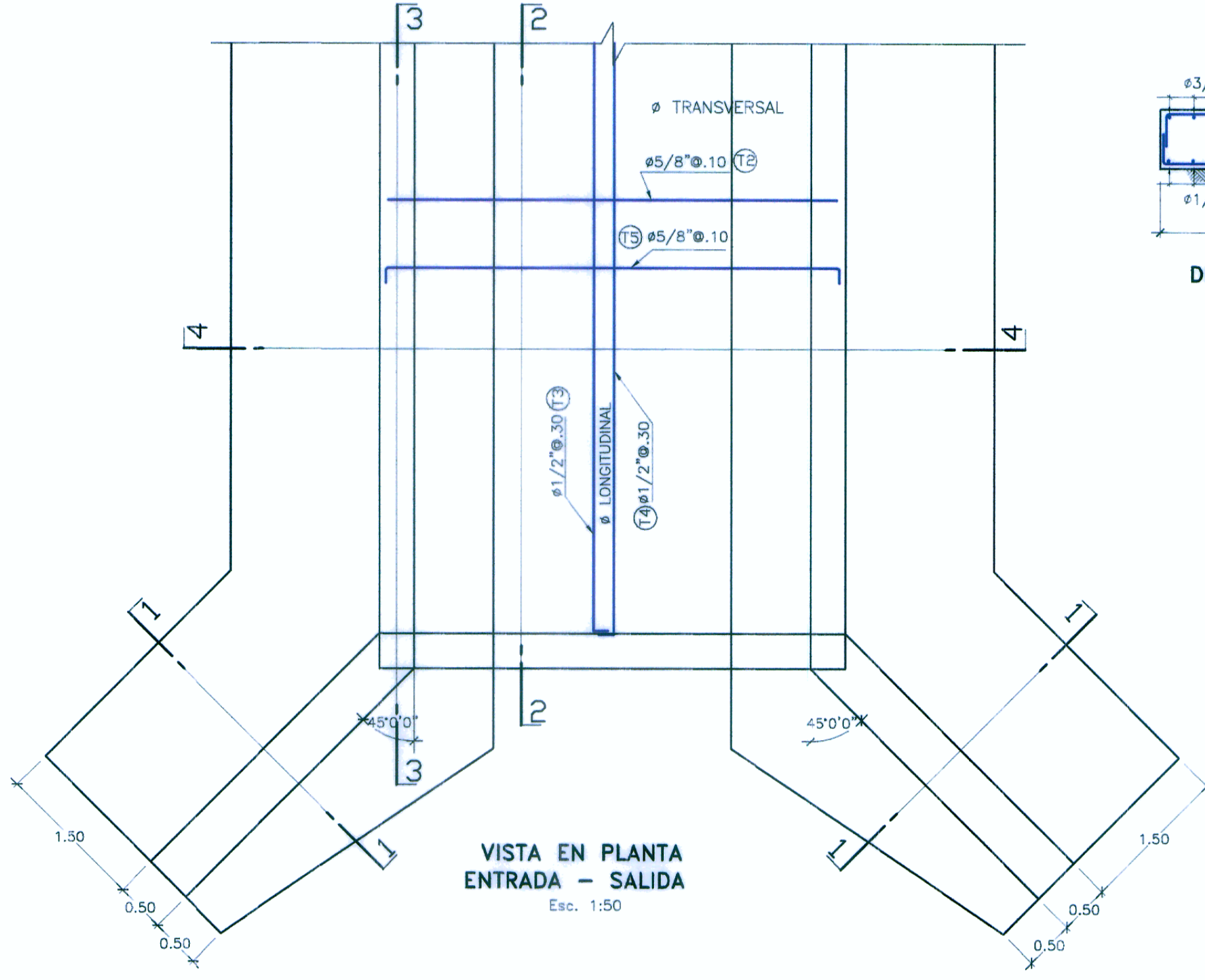

VISTA EN PLANTA ENTRADA - SALIDA
Esc. 1:50

ESPECIFICACIONES TECNICAS

CONCRETO ARMADO:
ZAPATA DE LA ALCANTARILLA $f_c=210$ Kg/cm²
PANTALLA DE LA ALCANTARILLA $f_c=210$ Kg/cm²

CONCRETO SIMPLE:
SOLADO $f_c=100$ Kg/cm²

ACERO:
ACERO CORRUGADO (GRADO 60) $f_y=4200$ Kg/cm².

RECUBRIMIENTOS LIBRES MINIMOS:
ZAPATA DE ALCANTARILLA : 7.5cm
ELEVACION DE ALCANTARILLA : 5.0cm
CARA INTERIOR : 5.0cm
CARA EXTERIOR : 5.0cm

DIAMETRO DE DOBLADO Y GANCHOS ESTANDAR MINIMOS

N° var (1/B')	DIAMETRO INTERIOR		GANCHO 180		GANCHO 90	
	cm	cm	cm	cm	cm	cm
3	5.6	6.25	11.30			
4	7.5	6.25	15.00			
5	9.4	6.25	18.80			
6	11.3	7.50	22.50			
8	15.0	10.00	30.00			

LONGITUD DE ANCLAJE MINIMO (m)

N° var (1/B')	ELEMENTOS EN COMPRESION		ELEMENTOS EN TRACCION	
	$f_c=210$ Kg/cm ²	$f_c=280$ Kg/cm ²	$f_c=210$ Kg/cm ²	$f_c=280$ Kg/cm ²
3	22.00	19.00	42.00	36.00
4	29.00	26.00	56.00	48.00
5	37.00	32.00	70.00	60.00
6	44.00	38.00	84.00	72.00
8	59.00	51.00	140.00	119.00

LONGITUD DE EMPALME MIN(m)

N° var (1/B')	ELEMENTOS EN COMPRESION		ELEMENTOS EN TRACCION	
	$f_c=210$ Kg/cm ²	$f_c=280$ Kg/cm ²	$f_c=210$ Kg/cm ²	$f_c=280$ Kg/cm ²
3	29.00	25.00	55.00	47.00
4	38.00	34.00	73.00	62.00
5	48.00	42.00	91.00	78.00
6	57.00	49.00	109.00	94.00
8	77.00	66.00	182.00	155.00

EDIFICACIONES DE DISEÑO Y CONSTRUCCION:
AASHTO LRFD 2004
REGLAMENTO NACIONAL DE EDIFICACIONES

HOB CONSULTORES S.A.

NOTA: LAS PRESENTES ESPECIFICACIONES SE COMPLEMENTAN CON LAS INDICADAS EN EL EXP. TECNICO

REVISIONES	
N°	FECHA DESCRIPCION