

COTA (M.S.N.M)

ESTRIBO	NIVEL-A	NIVEL-B	NIVEL-C	NIVEL-D	NIVEL-E	NIVEL-F
EI	-2.454	+10.546	+13.546	+14.981	+15.068	+15.120

FUERZAS AXIALES MAXIMAS TRANSMITIDAS A PILOTES

FUERZA AXIAL	ESTADO LIMITE DE RESISTENCIA
COMPRESION	210 Ton
TRACCION	--

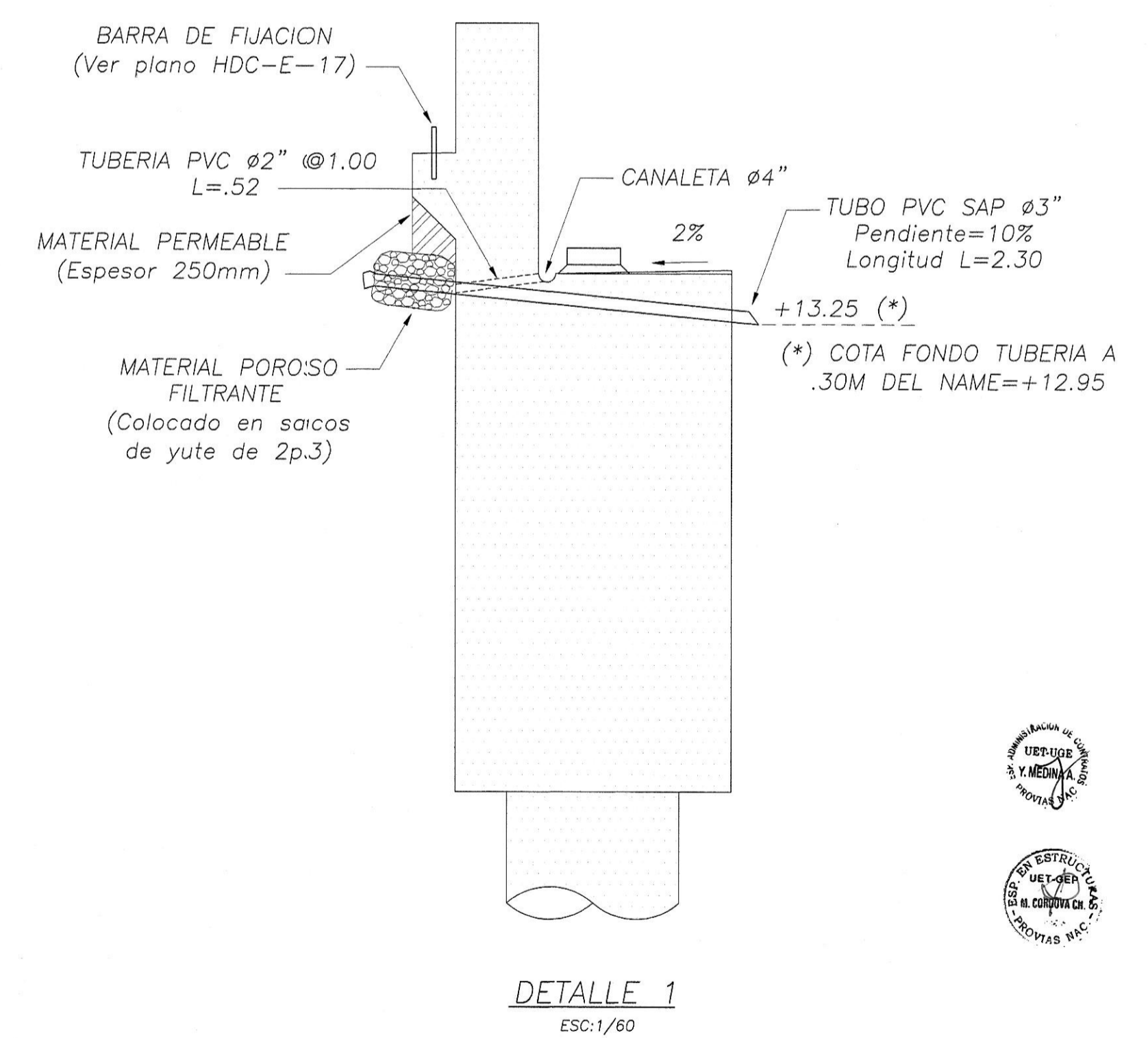
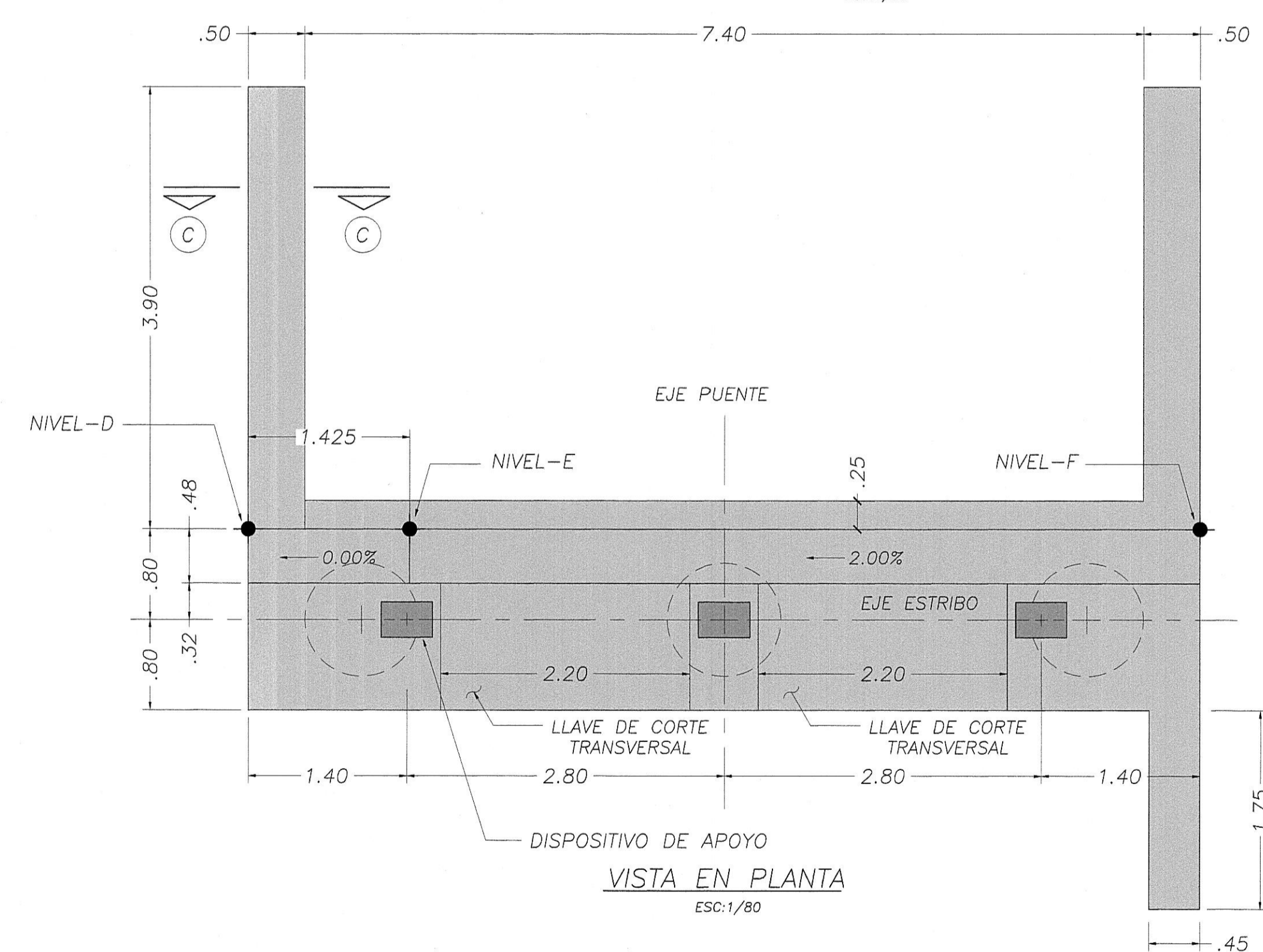

- NOTAS:**
1. Todas las dimensiones en metros (m) salvo se indique lo contrario.
 2. Todos los niveles en m.s.n.m.
 3. Escalas indicadas son para planos en formato A3.
Para planos en formato A1 las escalas son 50% de los valores indicados.