



HOJA DE CALCULO

Código:
Revisión:
Página: de
Especialidad: Estructuras

Proyecto: Estudio Definitivo de la Carretera: Camaná - Desvio Quilca - Matarani - Ilo - Tacna; Desvio Quilca - Matarani
Descripción del Trabajo: Diseño de Alcantarillas Tipo Marco 1.20 x 1.20

DESARROLLO

REFERENCIA

ALCANTARILLA TIPO MARCO 1.20 x 1.20 - PROG. 14+217.626

1.00 DATOS

A = 1.200 m
B = 1.200 m
t = 0.200 m
t1 = 0.150 m
h = 1.100 m
S/C = HL93 → P = 7.256 ton
e = 0.050 asfalto
f'c = 245 kg/cm²
pe rell. = 1.800 ton/m³
Ko = 0.450 coef. Emp. Tierra reposo
Ks = 1000 Coeficiente de Balasto

2.00 GEOMETRIA

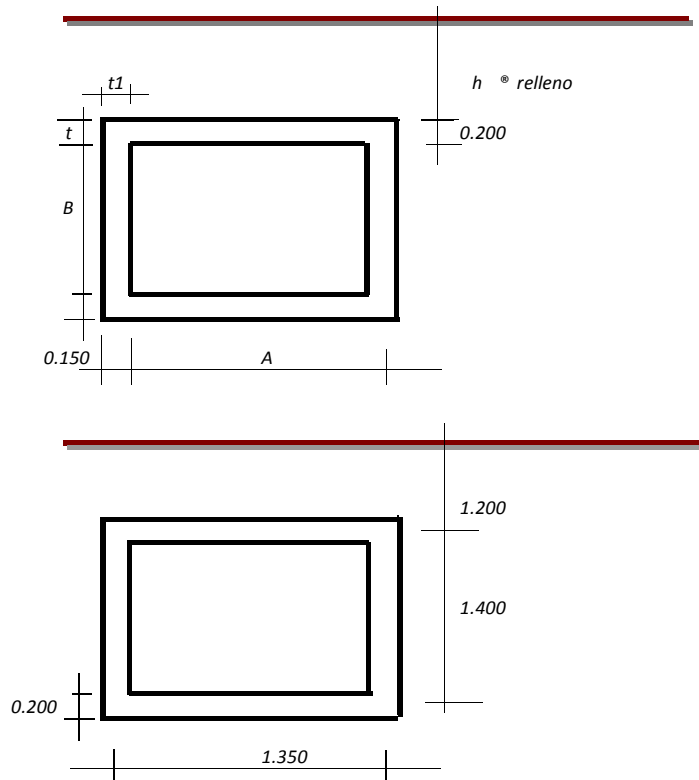



HOJA DE CALCULO

Código:
Revisión:
Página: de
Especialidad: Estructuras

Proyecto: Estudio Definitivo de la Carretera: Camaná - Desvio Quilca - Matarani - Ilo - Tacna; Desvio Quilca - Matarani
Descripción del Trabajo: Diseño de Alcantarillas Tipo Marco 1.20 x 1.20

DESARROLLO

REFERENCIA

3.00 METRADO DE CARGAS

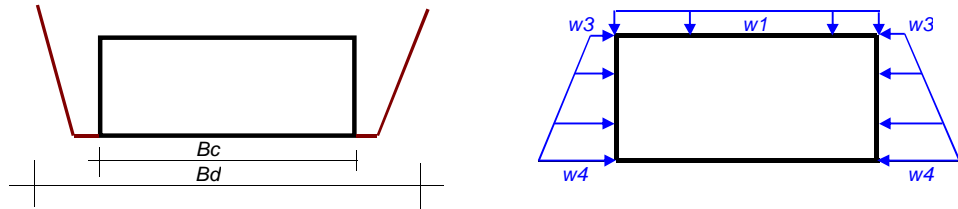

Bc = 1.500 m
H = 1.100 m

$$C_d = \frac{1 - e^{-2K_{\mu'} \frac{H}{B_d}}}{2K_{\mu'}}$$

Fe = 1.147

$$Fe = 1 + 0.20 \frac{H}{B_c}$$

$$w_2 = F_t \gamma_s H$$

w1 = 0.110 ton/m
w2 = 2.270 ton/m
w3 = 0.972 ton/m
w4 = 2.106 ton/m

Peso asfalto (DW)
Peso relleno (EV)
Empuje relleno (EH)

Impacto(I) = 1.181
w(LL+IM) = 4.477 ton/m

$$I = 1 + 0.33 \times (1 - 0.41H)$$

Sobrecarga (LL+IM)

4.00 ANALISIS

Resistencia I = 1.25 DC + 1.50 DW + 1.35 EV + (1.35 - 0.90) EH + 1.75 LL+IM
Servicio I = 1.00 DC + 1.00 DW + 1.00 EV + 1.00 EH + 1.00 LL+IM

4.10 Análisis por flexión

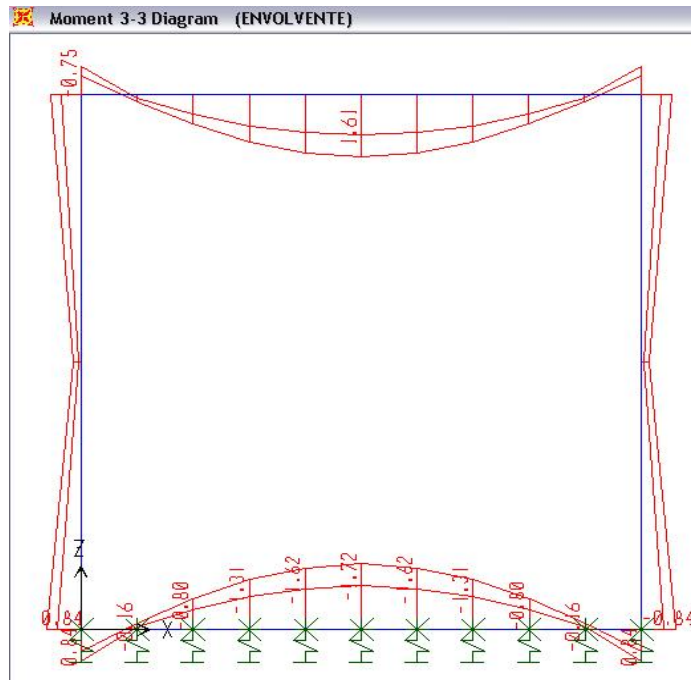
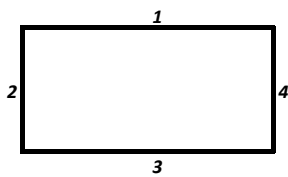



HOJA DE CALCULO

Código:
Revisión:
Página: de
Especialidad: Estructuras

Proyecto: Estudio Definitivo de la Carretera: Camaná - Desvío Quilca - Matarani - Ilo - Tacna; Desvío Quilca - Matarani
Descripción del Trabajo: Diseño de Alcantarillas Tipo Marco 1.20 x 1.20

DESARROLLO

REFERENCIA

4.20 Análisis por corte

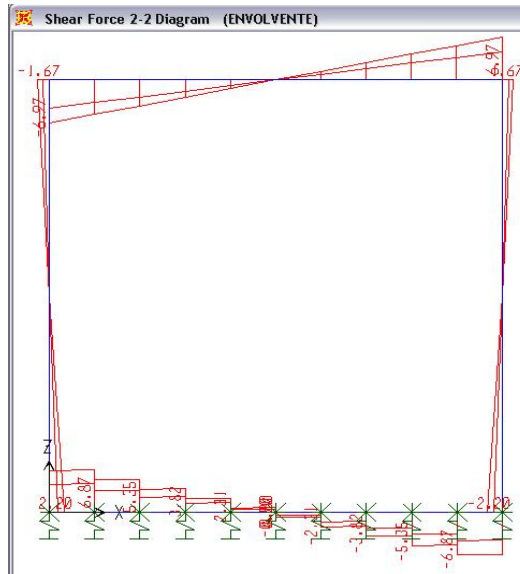

MOMENTOS DE DISEÑO

Barra 1 →	M- =	0.750	ton-m	M+ =	1.610	ton-m
Barra 2 →	M- =	0.840	ton-m	M+ =	0.001	ton-m
Barra 3 →	M- =	1.720	ton-m	M+ =	0.840	ton-m

5.00 DISEÑO DE MARCO

5.10 Por flexion

b=	100	cm.	f'c=	245	kg/cm2
d=	15	cm.	d=	10	cm (paredes)

✓ Refuerzo Calculado de los Momentos de Diseño

Barra	As - (cm2)	Varillas ϕ (")	@ (cm)	Usar S (cm)	As + (cm2)	Varillas ϕ (")	@ (cm)	Usar S (cm)
1	1.342	3/8	52.90	25.00	2.918	3/8	24.33	22.50
		1/2	96.11	25.00		1/2	44.21	25.00
		5/8	149.00	25.00		5/8	68.54	25.00
2	2.293	3/8	30.96	25.00	0.003	3/8	26728.58	25.00
		1/2	56.26	25.00		1/2	48563.19	25.00
		5/8	87.22	25.00		5/8	75291.76	25.00
3	3.122	3/8	22.74	22.50	1.505	3/8	47.17	25.00
		1/2	41.32	25.00		1/2	85.70	25.00
		5/8	64.06	25.00		5/8	132.87	25.00



HOJA DE CALCULO

Código:
Revisión:
Página: de
Especialidad: Estructuras

Proyecto: Estudio Definitivo de la Carretera: Camaná - Desvio Quilca - Matarani - Ilo - Tacna; Desvio Quilca - Matarani
Descripción del Trabajo: Diseño de Alcantarillas Tipo Marco 1.20 x 1.20

DESARROLLO

REFERENCIA

✓ **Mínimo Refuerzo**

$$f_r = 2\sqrt{f'c}$$

$$M_r = f_r \frac{bh^2}{6}$$

→

$f_r = 31.30 \text{ kg/cm}^2$

$M_r = 1.17 \text{ ton-m}$

$1.2 M_r = 1.41 \text{ ton-m}$

$$\text{Mínimo} = \begin{cases} \text{As (1.2 Mcr)} = 2.545 \text{ cm}^2 \\ 4/3 \text{ As} \end{cases}$$

Barra	As.mín - (cm2)	Varillas ϕ (")	@ (cm)	Usar S (cm)	As.mín + (cm2)	Varillas ϕ (")	@ (cm)	Usar S (cm)
1	1.800	3/8	39.44	25.00	2.545	3/8	27.89	25.00
		1/2	71.67	25.00		1/2	50.68	25.00
		5/8	111.11	25.00		5/8	78.57	25.00
2	2.545	3/8	27.89	25.00	1.800	3/8	39.44	25.00
		1/2	50.68	25.00		1/2	71.67	25.00
		5/8	78.57	25.00		5/8	111.11	25.00
3	2.545	3/8	27.89	25.00	2.007	3/8	35.38	25.00
		1/2	50.68	25.00		1/2	64.27	25.00
		5/8	78.57	25.00		5/8	99.65	25.00

✓ **Diseño Acero de Refuerzo**

$$\text{MÁX} = (As, As_{\text{mín}})$$

Barra	As - (cm2)	Varillas ϕ (")	@ (cm)	Usar S (cm)	As + (cm2)	Varillas ϕ (")	@ (cm)	Usar S (cm)
1	1.800	3/8	39.44	25.00	2.918	3/8	24.33	22.50
		1/2	71.67	25.00		1/2	44.21	25.00
		5/8	111.11	25.00		5/8	68.54	25.00
		∴ Utilizar	1/2	@		25.00	∴ Utilizar	1/2
2	2.545	3/8	27.89	25.00	1.800	3/8	39.44	25.00
		1/2	50.68	25.00		1/2	71.67	25.00
		5/8	78.57	25.00		5/8	111.11	25.00
		∴ Utilizar	1/2	@		25.00	∴ Utilizar	1/2
3	3.122	3/8	22.74	22.50	2.007	3/8	35.38	25.00
		1/2	41.32	25.00		1/2	64.27	25.00
		5/8	64.06	25.00		5/8	99.65	25.00
		∴ Utilizar	1/2	@		25.00	∴ Utilizar	1/2

5.20 Por corte

b= 100 cm
dmax= 30 cm
d consid= 15 cm

d critica= 0.38 (+ .15 chafan)
d'= 0.98

Vmax= 6.87 Ton del programa (SAP 2000)
Vud= 6870.00 Kg (Cortante de Diseño)

Vuc= 12462.85 Kg

∴ Vuc > Vud → **OK!!!**



HOJA DE CALCULO

Código:
Revisión:
Página: de
Especialidad: Estructuras

Proyecto: Estudio Definitivo de la Carretera: Camaná - Desvio Quilca - Matarani - Ilo - Tacna; Desvio Quilca - Matarani
Descripción del Trabajo: Diseño de Alcantarillas Tipo Marco 1.20 x 1.20

DESARROLLO

REFERENCIA

6.00 DISEÑO DE VIGA SARDINEL

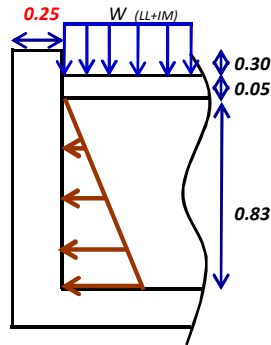

$f'_c = 245 \text{ Kg/cm}^2$
 $d = 20 \text{ cm}$
 $E_{DW} = 0.037 \text{ ton/m}$
 $E_H = 0.204 \text{ ton/m}$
 $E_{LL+IM} = 1.491 \text{ ton/m}$
 $\rightarrow V_u = 2.970 \text{ ton/m}$
 $V_c = 14.932 \text{ ton/m} > V_u \text{ OK!!!}$
 $M_{DW} = 0.015 \text{ ton-m/m}$
 $M_{EH} = 0.056 \text{ ton-m/m}$
 $M_{LL+IM} = 0.615 \text{ ton-m/m}$

$\rightarrow Mu = 1.183 \text{ ton/m}$
 $As = 1.586 \text{ cm}^2/\text{m}$

$\rightarrow \text{Usar } \phi \text{ } 1/2 \text{ "}$
 $\text{@ } 300 \text{ mm}$

7.00 PRESION TRANSMITIDA

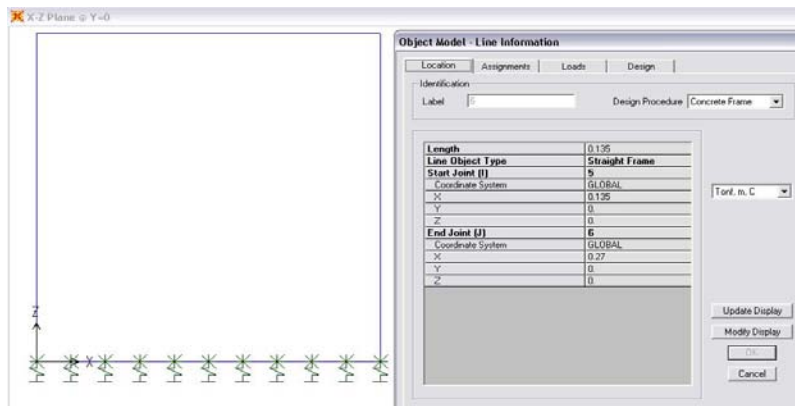

$P = 1.080 \text{ ton}$
 $AREA = 0.135 \text{ m}^2$

$$\text{Carga Transmitida} = \frac{\text{Fuerza}}{\text{Area}}$$

Carga Transmitida = 0.80 Kg/cm2





HOJA DE CALCULO

Código:
Revisión:
Página: de
Especialidad: Estructuras

Proyecto: Estudio Definitivo de la Carretera: Camaná - Desvio Quilca - Matarani - Ilo - Tacna; Desvio Quilca - Matarani
Descripción del Trabajo: Diseño de Alcantarillas Tipo Marco 1.20 x 1.20

DESARROLLO

REFERENCIA

ALAS

Altura máxima (m) = 1.95
Altura mínima (m) = 0.30

t(m) = 0.25

✓ E = 1.13 ton/m

ME = 0.734 ton-m/m

Mu = 1.10 ton-m/m

b = 100.00 cm

d = 19.00 cm

f'c = 245.00 Kg/cm²

→ As = 1.55 cm²

✓ **Mínimo Refuerzo**

$$As_{min} = \min \left[\frac{4}{3} As, As(1.2Mr) \right]$$

✓ **Calculo de Mr**

$$f_r = 2\sqrt{f'c}$$

$$Mr = fr \frac{bh^2}{6}$$

→

fr = 31.30 kg/cm²

Mr = 3.95 ton-m

1.2 Mr = 4.73 ton-m

→ As (1.2Mr) = 6.92 cm²

4/3 As = 2.07 cm²

As.min = 2.07 cm²

→ **Acero de Diseño = 2.25 cm²**

→

1/2 " @ 300 mm

