



## HOJA DE CALCULO

Código:  
Revisión:  
Página: de  
Especialidad: Estructuras

Proyecto: Estudio Definitivo de la Carretera: Camaná - Desvio Quilca - Matarani - Ilo - Tacna; Desvio Quilca - Matarani  
Descripción del Trabajo: Diseño de Alcantarillas Tipo Marco 2.00 x 1.50

DESARROLLO

REFERENCIA

### ALCANTARILLA TIPO MARCO 2.00 x 1.50 - PROG. 18+506.232

#### 1.00 DATOS

A = 2.000 m  
B = 1.500 m  
t = 0.250 m  
t1 = 0.200 m  
h = 0.250 m  
S/C = HL93 → P = 7.256 ton  
e = 0.050 asfalto  
f'c = 245 kg/cm<sup>2</sup>  
pe rell. = 1.800 ton/m<sup>3</sup>  
Ko = 0.450 coef. Emp. Tierra reposo  
Ks = 8000 Coeficiente de Balasto (ton/m<sup>3</sup>)

#### 2.00 GEOMETRIA

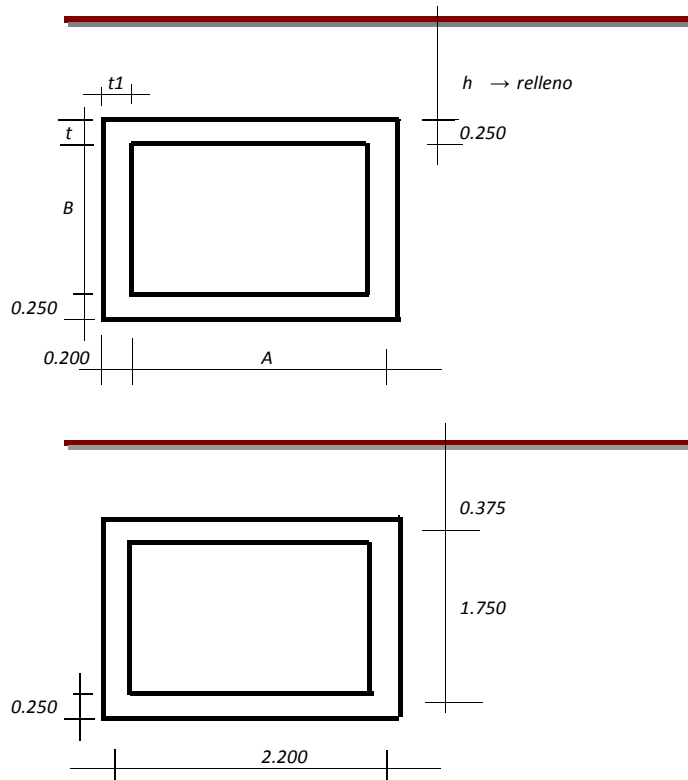



HOJA DE CALCULO

Código:  
Revisión:  
Página: de  
Especialidad: Estructuras

Proyecto: Estudio Definitivo de la Carretera: Camaná - Desvio Quilca - Matarani - Ilo - Tacna; Desvio Quilca - Matarani  
Descripción del Trabajo: Diseño de Alcantarillas Tipo Marco 2.00 x 1.50

DESARROLLO

REFERENCIA

3.00 METRADO DE CARGAS

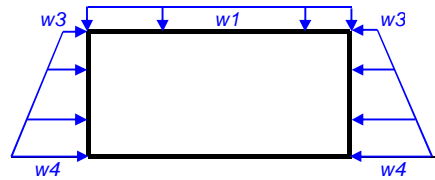
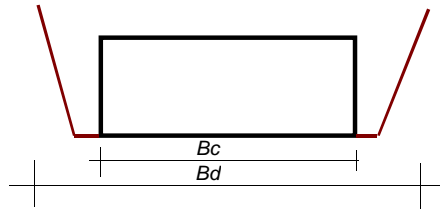

Bc= 2.400 m  
H= 0.250 m

$$C_d = \frac{1 - e^{-2K_{\mu'} \frac{H}{B_d}}}{2K_{\mu'}}$$

Fe = 1.021

$$F_e = 1 + 0.20 \frac{H}{B_c}$$

$$w_2 = F_e \gamma_s H$$

w1 = 0.110 ton/m  
w2 = 0.459 ton/m  
w3 = 0.304 ton/m  
w4 = 1.721 ton/m

Peso asfalto (DW)  
Peso relleno (EV)  
Empuje relleno (EH)

Impacto(I) = 1.33  
E+ = 1.870 m  
E- = 1.770 m

4.00 ANALISIS

Resistencia I = 1.25 DC + 1.50 DW + 1.35 EV + (1.35 - 0.90) EH + 1.75 LL+IM  
Servicio I = 1.00 DC + 1.00 DW + 1.00 EV + 1.00 EH + 1.00 LL+IM

4.10 Análisis por flexión

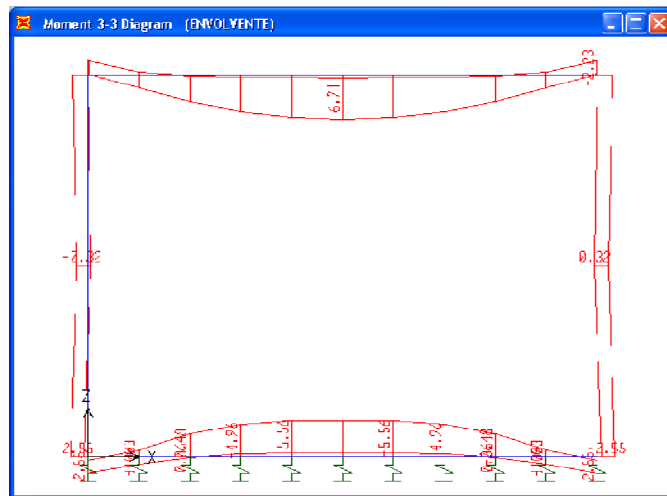
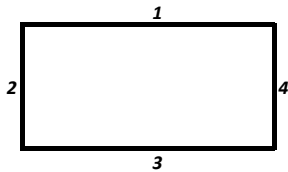



HOJA DE CALCULO

Código:  
Revisión:  
Página: de  
Especialidad: Estructuras

Proyecto: Estudio Definitivo de la Carretera: Camaná - Desvío Quilca - Matarani - Ilo - Tacna; Desvío Quilca - Matarani  
Descripción del Trabajo: Diseño de Alcantarillas Tipo Marco 2.00 x 1.50

DESARROLLO

REFERENCIA

4.20 Análisis por corte

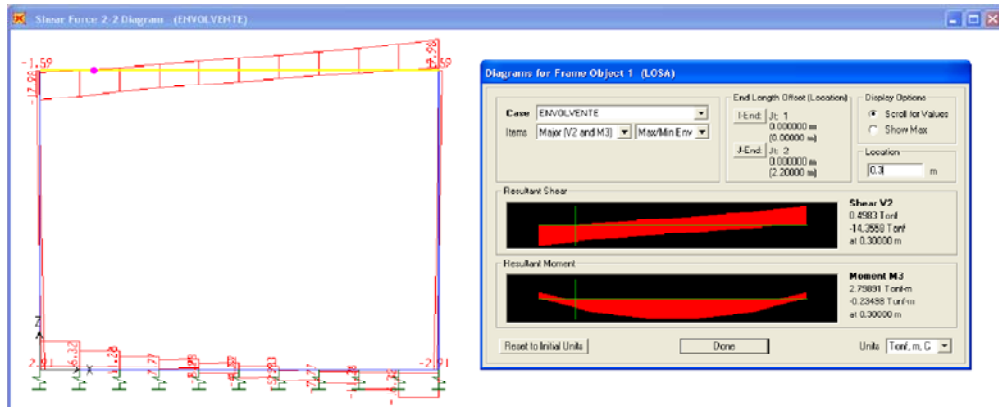

**MOMENTOS DE DISEÑO**

Barra 1 →	M- =	2.230	ton-m	M+ =	6.710	ton-m
Barra 2 →	M- =	2.550	ton-m	M+ =	0.320	ton-m
Barra 3 →	M- =	5.560	ton-m	M+ =	2.550	ton-m

5.00 DISEÑO DE MARCO

5.10 Por flexion

b=	100	cm.	f'c=	245	kg/cm <sup>2</sup>
d=	20	cm.	d=	15	cm (paredes)

✓ Refuerzo Calculado de los Momentos de Diseño

Barra	As - (cm <sup>2</sup> )	Varillas φ (")	@ (cm)	Usar S (cm)	As + (cm <sup>2</sup> )	Varillas φ (")	@ (cm)	Usar S (cm)
1	3.015	3/8	23.55	22.50	9.435	3/8	7.52	7.50
		1/2	42.78	25.00		1/2	13.67	12.50
		5/8	66.33	25.00		5/8	21.20	20.00
2	4.688	3/8	15.15	15.00	0.569	3/8	124.73	25.00
		1/2	27.52	25.00		1/2	226.63	25.00
		5/8	42.66	25.00		5/8	351.37	25.00
3	7.736	3/8	9.18	7.50	3.457	3/8	20.54	20.00
		1/2	16.67	15.00		1/2	37.32	25.00
		5/8	25.85	25.00		5/8	57.85	25.00



## HOJA DE CALCULO

Código:  
Revisión:  
Página: de  
Especialidad: Estructuras

Proyecto: Estudio Definitivo de la Carretera: Camaná - Desvio Quilca - Matarani - Ilo - Tacna; Desvio Quilca - Matarani  
Descripción del Trabajo: Diseño de Alcantarillas Tipo Marco 2.00 x 1.50

### DESARROLLO

### REFERENCIA

#### ✓ Mínimo Refuerzo

$$f_r = 2\sqrt{f'c}$$

$$M_r = f_r \frac{bh^2}{6}$$

Mínimo =

$$\left\{ \begin{array}{l} As (1.2 M_{cr}) = 3.394 \text{ cm}^2 \\ 4/3 As \end{array} \right.$$

$$\rightarrow \begin{array}{ll} f_r = & 31.30 \text{ kg/cm}^2 \\ M_r = & 2.09 \text{ ton-m} \\ 1.2 M_r = & 2.50 \text{ ton-m} \end{array}$$

Barra	As.mín - (cm2)	Varillas $\phi$ (")	@ (cm)	Usar S (cm)	As.mín + (cm2)	Varillas $\phi$ (")	@ (cm)	Usar S (cm)
1	3.394	3/8	20.92	20.00	3.394	3/8	20.92	20.00
		1/2	38.01	25.00		1/2	38.01	25.00
		5/8	58.93	25.00		5/8	58.93	25.00
2	3.394	3/8	20.92	20.00	1.800	3/8	39.44	25.00
		1/2	38.01	25.00		1/2	71.67	25.00
		5/8	58.93	25.00		5/8	111.11	25.00
3	3.394	3/8	20.92	20.00	3.394	3/8	20.92	20.00
		1/2	38.01	25.00		1/2	38.01	25.00
		5/8	58.93	25.00		5/8	58.93	25.00

#### ✓ Diseño Acero de Refuerzo

$$MÁX = (As, As_{mín})$$

Barra	As - (cm2)	Varillas $\phi$ (")	@ (cm)	Usar S (cm)	As + (cm2)	Varillas $\phi$ (")	@ (cm)	Usar S (cm)
1	3.394	3/8	20.92	20.00	9.435	3/8	7.52	7.50
		1/2	38.01	25.00		1/2	13.67	12.50
		5/8	58.93	25.00		5/8	21.20	20.00
	∴ Utilizar	1/2	@	25.00	∴ Utilizar	5/8	@	20.00
2	4.688	3/8	15.15	15.00	1.800	3/8	39.44	25.00
		1/2	27.52	25.00		1/2	71.67	25.00
		5/8	42.66	25.00		5/8	111.11	25.00
	∴ Utilizar	1/2	@	25.00	∴ Utilizar	1/2	@	25.00
3	7.736	3/8	9.18	7.50	3.457	3/8	20.54	20.00
		1/2	16.67	15.00		1/2	37.32	25.00
		5/8	25.85	25.00		5/8	57.85	25.00
	∴ Utilizar	5/8	@	25.00	∴ Utilizar	1/2	@	25.00

#### 5.20 Por corte

b= 100 cm  
dmax= 35 cm  
d consid= 20 cm

d critica= 0.45 (+ .15 chafan)  
d' = 1.75

Vmax= 13.98 Ton del programa (SAP 2000)  
Vud= 13980.00 Kg (Cortante de Diseño)

Vuc= 16581.33 Kg

∴ Vuc > Vud → **OK!!!**



HOJA DE CALCULO

Código:  
Revisión:  
Página: de  
Especialidad: Estructuras

Proyecto: Estudio Definitivo de la Carretera: Camaná - Desvio Quilca - Matarani - Ilo - Tacna; Desvio Quilca - Matarani  
Descripción del Trabajo: Diseño de Alcantarillas Tipo Marco 2.00 x 1.50

DESARROLLO

REFERENCIA

6.00 DISEÑO DE VIGA SARDINEL

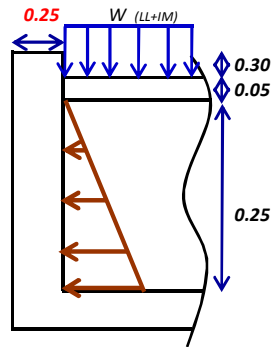

$f'_c = 245 \text{ Kg/cm}^2$   
 $d = 20 \text{ cm}$   
 $E_{DW} = 0.037 \text{ ton/m}$   
 $E_H = 0.019 \text{ ton/m}$   
 $E_{LL+IM} = 2.416 \text{ ton/m}$   
 $\rightarrow V_u = 4.311 \text{ ton/m}$   
 $V_c = 14.932 \text{ ton/m} > V_u \text{ OK!!!}$   
 $M_{DW} = 0.005 \text{ ton-m/m}$   
 $M_{EH} = 0.002 \text{ ton-m/m}$   
 $M_{LL+IM} = 0.302 \text{ ton-m/m}$

$\rightarrow Mu = 0.538 \text{ ton/m}$   
 $As = 0.717 \text{ cm}^2/\text{m}$

$\rightarrow \text{Usar } \phi \text{ } 1/2 \text{ "}$   
 $\text{ @ } 300 \text{ mm}$

7.00 PRESION TRANSMITIDA

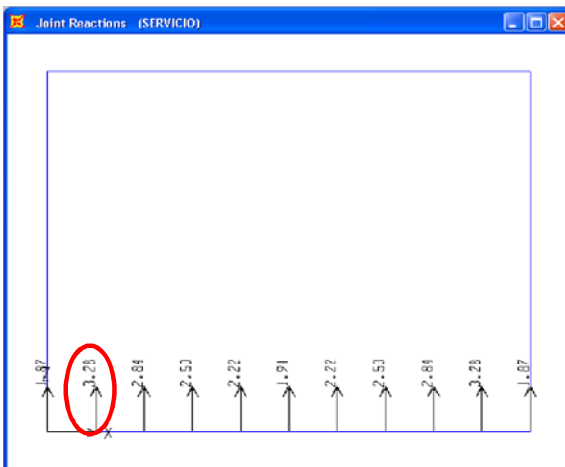
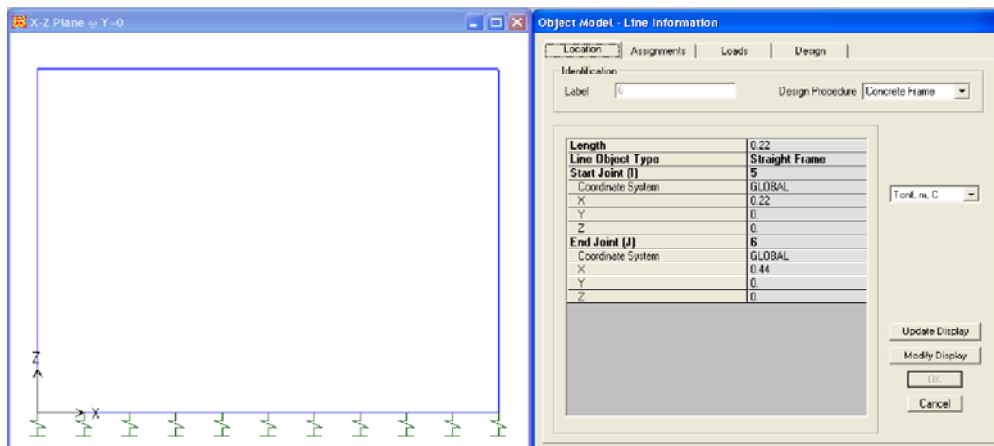

$P = 3.280 \text{ ton}$   
 $AREA = 0.220 \text{ m}^2$

$$\text{Carga Transmitida} = \frac{\text{Fuerza}}{\text{Area}}$$

Carga Transmitida = 1.49 Kg/cm<sup>2</sup>



HOJA DE CALCULO

Código:  
Revisión:  
Página: de  
Especialidad: Estructuras

Proyecto: Estudio Definitivo de la Carretera: Camaná - Desvio Quilca - Matarani - Ilo - Tacna; Desvio Quilca - Matarani  
Descripción del Trabajo: Diseño de Alcantarillas Tipo Marco 2.00 x 1.50

DESARROLLO

REFERENCIA

**ALAS**

Altura máxima (m) = 1.80  
Altura mínima (m) = 0.20

t(m) = 0.25

✓ E = 0.96 ton/m ME = 0.577 ton-m/m  
Mu = 0.87 ton-m/m  
b = 100.00 cm f'c = 245.00 Kg/cm2  
d = 19.00 cm → As = 1.22 cm2

✓ **Mínimo Refuerzo**

$$As_{min} = \min \left[ \frac{4}{3} As, As(1.2Mr) \right]$$

✓ **Calculo de Mr**

$$f_r = 2\sqrt{f'c}$$

$$M_r = fr \frac{bh^2}{6}$$

→ fr = 31.30 kg/cm2  
Mr = 3.95 ton-m  
1.2 Mr = 4.73 ton-m

→ As (1.2Mr) = 6.92 cm2  
4/3 As = 1.63 cm2

As.min = 1.63 cm2

→ **Acero de Diseño = 2.25 cm2**

→ 1/2 " @ 300 mm

