



## HOJA DE CALCULO

Código:  
Revisión:  
Página: de  
Especialidad: Estructuras

Proyecto: Estudio Definitivo de la Carretera: Camaná - Desvio Quilca - Matarani - Ilo - Tacna; Desvio Quilca - Matarani  
Descripción del Trabajo: Diseño de Alcantarillas Tipo Marco 1.50 x 1.20

DESARROLLO

REFERENCIA

### ALCANTARILLA TIPO MARCO 1.50 x 1.20 - PROG. 26+686.001

#### 1.00 DATOS

A = 1.500 m  
B = 1.200 m  
t = 0.250 m  
t1 = 0.200 m  
h = 5.230 m  
S/C = HL93 → P = 7.256 ton  
e = 0.050 asfalto  
f'c = 245 kg/cm<sup>2</sup>  
pe rell. = 1.800 ton/m<sup>3</sup>  
Ko = 0.450 coef. Emp. Tierra reposo  
Ks = 1000 Coeficiente de Balasto

#### 2.00 GEOMETRIA

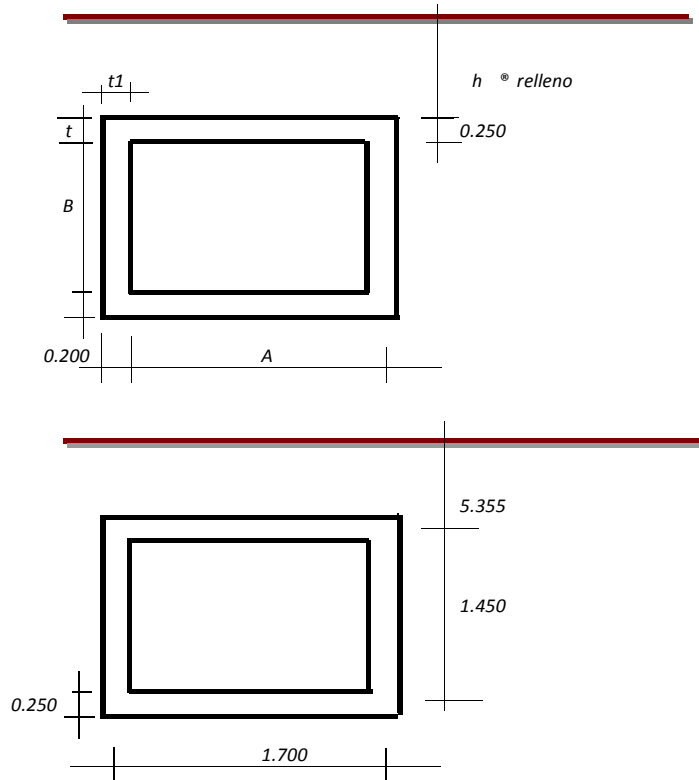



HOJA DE CALCULO

Código:  
Revisión:  
Página: de  
Especialidad: Estructuras

Proyecto: Estudio Definitivo de la Carretera: Camaná - Desvío Quilca - Matarani - Ilo - Tacna; Desvío Quilca - Matarani  
Descripción del Trabajo: Diseño de Alcantarillas Tipo Marco 1.50 x 1.20

DESARROLLO

REFERENCIA

3.00 METRADO DE CARGAS

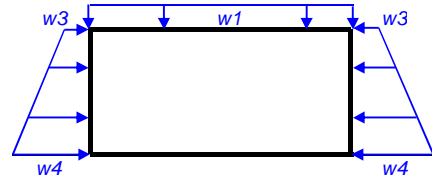
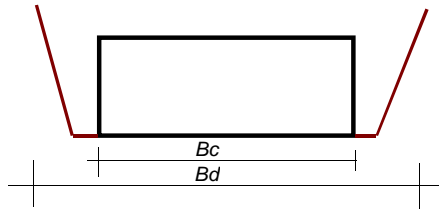

Bc= 1.900 m  
H= 5.230 m  
Bd= 2.900 m  
H/Bd= 1.803

$$C_d = \frac{1 - e^{-2K_{\mu'} \frac{H}{B_d}}}{2K_{\mu'}}$$

Fe = 1.150

$$Fe = 1 + 0.20 \frac{H}{B_c}$$

$$w_2 = F_e \gamma_s H$$

w1 = 0.110 ton/m  
w2 = 10.826 ton/m  
w3 = 4.338 ton/m  
w4 = 5.512 ton/m

Peso asfalto (DW)  
Peso relleno (EV)  
Empuje relleno (EH)

Impacto(I) = 1.000  
w(LL+IM) = 0.514 ton/m

$$I = 1 + 0.33 \times (1 - 0.41H)$$

Sobrecarga (LL+IM)

4.00 ANALISIS

Resistencia I = 1.25 DC + 1.50 DW + 1.35 EV + (1.35 - 0.90) EH + 1.75 LL+IM  
Servicio I = 1.00 DC + 1.00 DW + 1.00 EV + 1.00 EH + 1.00 LL+IM

4.10 Análisis por flexión

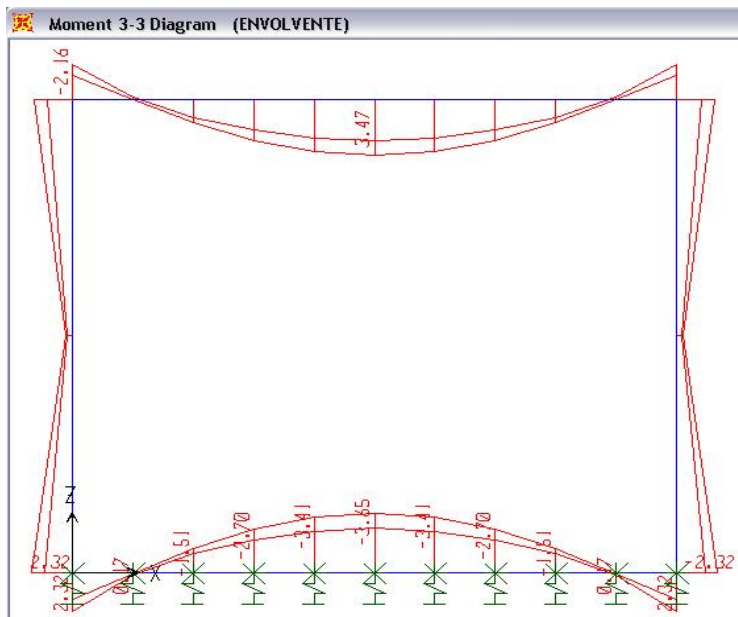
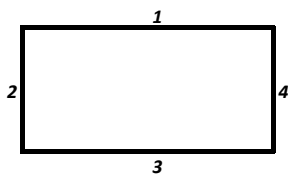



HOJA DE CALCULO

Código:  
Revisión:  
Página: de  
Especialidad: Estructuras

Proyecto: Estudio Definitivo de la Carretera: Camaná - Desvío Quilca - Matarani - Ilo - Tacna; Desvío Quilca - Matarani  
Descripción del Trabajo: Diseño de Alcantarillas Tipo Marco 1.50 x 1.20

DESARROLLO

REFERENCIA

4.20 Análisis por corte

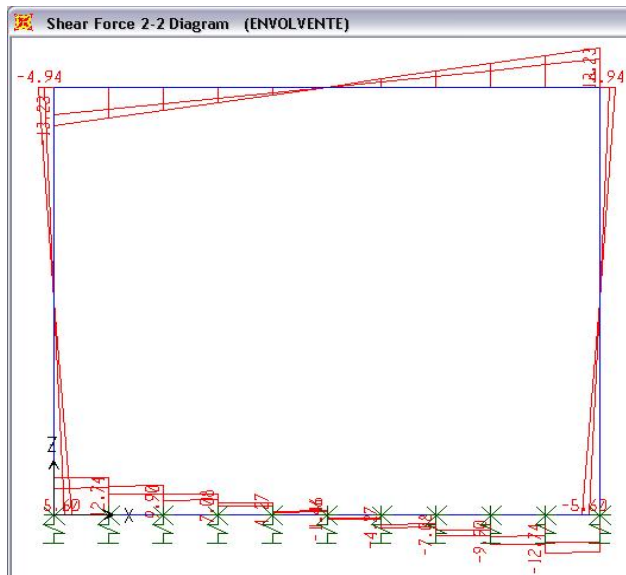

**MOMENTOS DE DISEÑO**

Barra 1 →	M- =	2.160	ton-m	M+ =	3.470	ton-m
Barra 2 →	M- =	2.320	ton-m	M+ =	0.001	ton-m
Barra 3 →	M- =	3.650	ton-m	M+ =	2.320	ton-m

**5.00 DISEÑO DE MARCO**

5.10 Por flexion

b=	100	cm.	f'c=	245	kg/cm <sup>2</sup>
d=	20	cm.	d=	15	cm (paredes)

✓ Refuerzo Calculado de los Momentos de Diseño

Barra	As - (cm <sup>2</sup> )	Varillas φ (")	@ (cm)	Usar S (cm)	As + (cm <sup>2</sup> )	Varillas φ (")	@ (cm)	Usar S (cm)
1	2.919	3/8	24.32	22.50	4.741	3/8	14.98	12.50
		1/2	44.20	25.00		1/2	27.21	25.00
		5/8	68.52	25.00		5/8	42.19	25.00
2	4.250	3/8	16.71	15.00	0.002	3/8	40093.56	25.00
		1/2	30.35	25.00		1/2	72846.05	25.00
		5/8	47.06	25.00		5/8	112939.61	25.00
3	4.994	3/8	14.22	12.50	3.139	3/8	22.62	22.50
		1/2	25.83	25.00		1/2	41.09	25.00
		5/8	40.04	25.00		5/8	63.71	25.00



## HOJA DE CALCULO

Código:  
Revisión:  
Página: de  
Especialidad: Estructuras

Proyecto: Estudio Definitivo de la Carretera: Camaná - Desvio Quilca - Matarani - Ilo - Tacna; Desvio Quilca - Matarani  
Descripción del Trabajo: Diseño de Alcantarillas Tipo Marco 1.50 x 1.20

**DESARROLLO**

**REFERENCIA**

✓ **Mínimo Refuerzo**

$$f_r = 2\sqrt{f'c}$$

$$M_r = f_r \frac{bh^2}{6}$$

$$\rightarrow \begin{aligned} f_r &= 31.30 \text{ kg/cm}^2 \\ M_r &= 2.09 \text{ ton-m} \\ 1.2 M_r &= 2.50 \text{ ton-m} \end{aligned}$$

$$\text{Mínimo} = \begin{cases} \text{As (1.2 Mcr)} = 3.394 \text{ cm}^2 \\ 4/3 \text{ As} \end{cases}$$

Barra	As.mín - (cm2)	Varillas $\phi$ (")	@ (cm)	Usar S (cm)	As.mín + (cm2)	Varillas $\phi$ (")	@ (cm)	Usar S (cm)
1	3.394	3/8	20.92	20.00	3.394	3/8	20.92	20.00
		1/2	38.01	25.00		1/2	38.01	25.00
		5/8	58.93	25.00		5/8	58.93	25.00
2	3.394	3/8	20.92	20.00	2.250	3/8	31.56	25.00
		1/2	38.01	25.00		1/2	57.33	25.00
		5/8	58.93	25.00		5/8	88.89	25.00
3	3.394	3/8	20.92	20.00	3.394	3/8	20.92	20.00
		1/2	38.01	25.00		1/2	38.01	25.00
		5/8	58.93	25.00		5/8	58.93	25.00

✓ **Diseño Acero de Refuerzo**

$$\text{MÁX} = (As, As_{\text{mín}})$$

Barra	As - (cm2)	Varillas $\phi$ (")	@ (cm)	Usar S (cm)	As + (cm2)	Varillas $\phi$ (")	@ (cm)	Usar S (cm)
1	3.394	3/8	20.92	20.00	4.741	3/8	14.98	12.50
		1/2	38.01	25.00		1/2	27.21	25.00
		5/8	58.93	25.00		5/8	42.19	25.00
	∴ Utilizar	1/2	@	25.00	∴ Utilizar	1/2	@	25.00
2	4.250	3/8	16.71	15.00	2.250	3/8	31.56	25.00
		1/2	30.35	25.00		1/2	57.33	25.00
		5/8	47.06	25.00		5/8	88.89	25.00
	∴ Utilizar	1/2	@	25.00	∴ Utilizar	1/2	@	25.00
3	4.994	3/8	14.22	12.50	3.394	3/8	20.92	20.00
		1/2	25.83	25.00		1/2	38.01	25.00
		5/8	40.04	25.00		5/8	58.93	25.00
	∴ Utilizar	1/2	@	25.00	∴ Utilizar	1/2	@	25.00

**5.20 Por corte**

b= 100 cm  
dmax= 35 cm  
d consid= 20 cm

d critica= 0.45 (+ .15 chafan)  
d'= 1.25

Vmax= 12.74 Ton del programa (SAP 2000)  
Vud= 12740.00 Kg (Cortante de Diseño)

Vuc= 16897.78 Kg

∴ Vuc > Vud → **OK!!!**



HOJA DE CALCULO

Código:  
Revisión:  
Página: de  
Especialidad: Estructuras

Proyecto: Estudio Definitivo de la Carretera: Camaná - Desvío Quilca - Matarani - Ilo - Tacna; Desvío Quilca - Matarani  
Descripción del Trabajo: Diseño de Alcantarillas Tipo Marco 1.50 x 1.20

DESARROLLO

REFERENCIA

6.00 DISEÑO DE VIGA SARDINEL

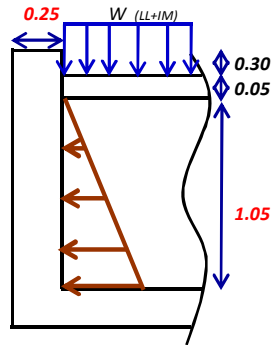

$f'c = 245 \text{ Kg/cm}^2$   
 $d = 20 \text{ cm}$   
 $E_{DW} = 0.037 \text{ ton/m}$   
 $E_H = 0.330 \text{ ton/m}$   
 $E_{LL+IM} = 0.171 \text{ ton/m}$   
 $\rightarrow V_u = 0.850 \text{ ton/m}$   
 $V_c = 14.932 \text{ ton/m} > V_u \text{ OK!!!}$   
 $M_{DW} = 0.019 \text{ ton-m/m}$   
 $M_{EH} = 0.116 \text{ ton-m/m}$   
 $M_{LL+IM} = 0.090 \text{ ton-m/m}$

$\rightarrow Mu = 0.360 \text{ ton/m}$   
 $As = 0.479 \text{ cm}^2/\text{m}$

$\rightarrow \text{Usar } \phi \text{ } 1/2 \text{ "}$   
 $\text{@ } 300 \text{ mm}$

7.00 PRESION TRANSMITIDA

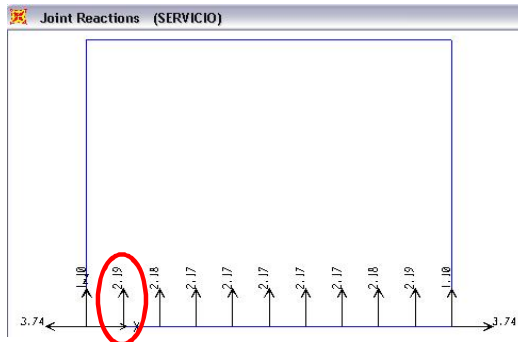
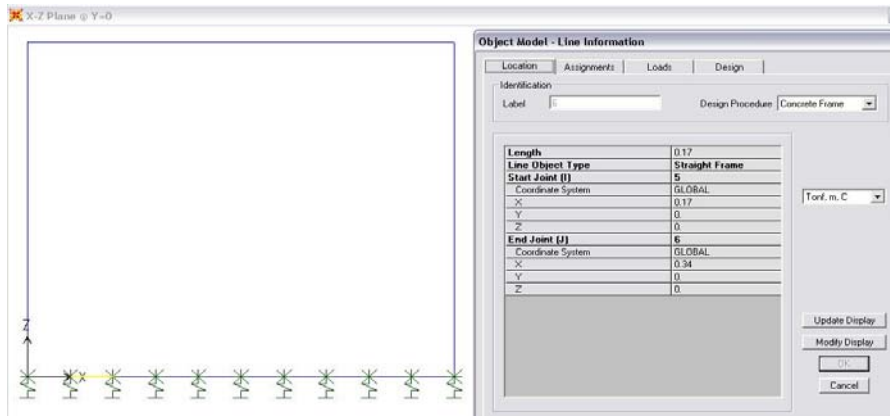

$P = 2.190 \text{ ton}$   
 $AREA = 0.170 \text{ m}^2$

$$\text{Carga Transmitida} = \frac{\text{Fuerza}}{\text{Area}}$$

Carga Transmitida = 1.29 Kg/cm<sup>2</sup>



HOJA DE CALCULO

Código:  
Revisión:  
Página: de  
Especialidad: Estructuras

Proyecto: Estudio Definitivo de la Carretera: Camaná - Desvio Quilca - Matarani - Ilo - Tacna; Desvio Quilca - Matarani  
Descripción del Trabajo: Diseño de Alcantarillas Tipo Marco 1.50 x 1.20

DESARROLLO

REFERENCIA

**ALAS**

Altura máxima (m) = 1.90  
Altura mínima (m) = 0.60

t(m) = 0.25

✓ E = 1.07 ton/m ME = 0.679 ton-m/m  
Mu = 1.02 ton-m/m  
b = 100.00 cm f'c = 245.00 Kg/cm2  
d = 19.00 cm → As = 1.44 cm2

✓ **Mínimo Refuerzo**

$$As_{min} = \min \left[ \frac{4}{3} As, As(1.2Mr) \right]$$

✓ **Calculo de Mr**

$$f_r = 2\sqrt{f'c}$$

$$M_r = fr \frac{bh^2}{6}$$

→ fr = 31.30 kg/cm2  
Mr = 3.95 ton-m  
1.2 Mr = 4.73 ton-m

→ As (1.2Mr) = 6.92 cm2  
4/3 As = 1.92 cm2

As.min = 1.92 cm2

→ **Acero de Diseño = 2.25 cm2**

→ 1/2 " @ 300 mm

