



HOJA DE CALCULO

Código:
 Revisión:
 Página: de
 Especialidad: Estructuras

Proyecto: Estudio Definitivo de la Carretera: Camaná - Desvio Quilca - Matarani - Ilo - Tacna; Desvio Quilca - Matarani
 Descripción del Trabajo: Diseño de Alcantarillas Tipo Marco 1.00 x 1.00

DESARROLLO

REFERENCIA

ALCANTARILLA TIPO MARCO 1.00 x 1.00 - PROG. 38+363.428

1.00 DATOS

A =	1.000	m		
B =	1.000	m		
R =	0.500	m		
t =	0.250	m		
t1 =	0.250	m		
e =	0.250			
h =	10.650	m		
S/C =	HL93	→	P =	7.256 ton
e =	0.050	asfalto		
f'c =	245	kg/cm ²		
pe rell. =	1.800	ton/m ³		
Ko =	0.450	coef. Emp. Tierra reposo		
Ks =	1000	Coficiente de Balasto		

2.00 GEOMETRIA

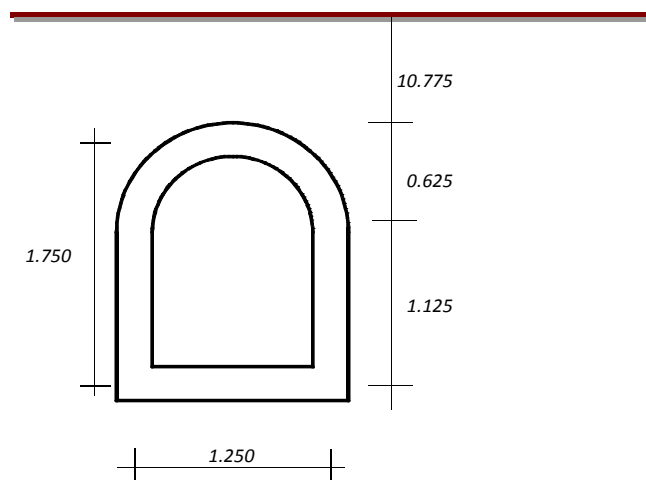
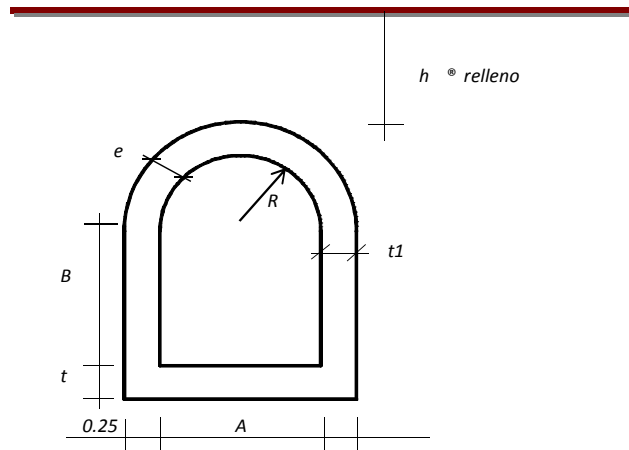



HOJA DE CALCULO

Código:
Revisión:
Página: de
Especialidad: Estructuras

Proyecto: Estudio Definitivo de la Carretera: Camaná - Desvio Quilca - Matarani - Ilo - Tacna; Desvio Quilca - Matarani
Descripción del Trabajo: Diseño de Alcantarillas Tipo Marco 1.00 x 1.00

DESARROLLO

REFERENCIA

3.00 METRADO DE CARGAS

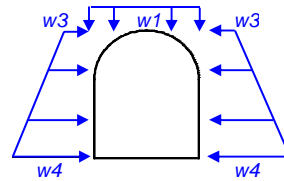
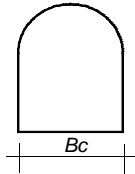

Bc= 1.500 m
H= 10.650 m

$$C_d = \frac{1 - e^{-2K_{\mu'} \frac{H}{B_d}}}{2K_{\mu'}}$$

Fe = 1.150

$$Fe = 1 + 0.20 \frac{H}{B_c}$$

$$w_2 = F_t \gamma_s H$$

w1 = 0.110 ton/m
w2 = 22.046 ton/m
w3 = 8.728 ton/m
w4 = 9.639 ton/m

Peso asfalto (DW)
Peso relleno (EV)
Empuje relleno (EH)

Impacto(I) = 1.000
w (LL+IM) = 0.163 ton/m

$$I = 1 + 0.33 \times (1 - 0.41H)$$

Sobrecarga (LL+IM)

4.00 ANALISIS

Resistencia I = 1.25 DC + 1.50 DW + 1.35 EV + (1.35 - 0.90) EH + 1.75 LL+IM
Servicio I = 1.00 DC + 1.00 DW + 1.00 EV + 1.00 EH + 1.00 LL+IM

4.10 Análisis por flexión

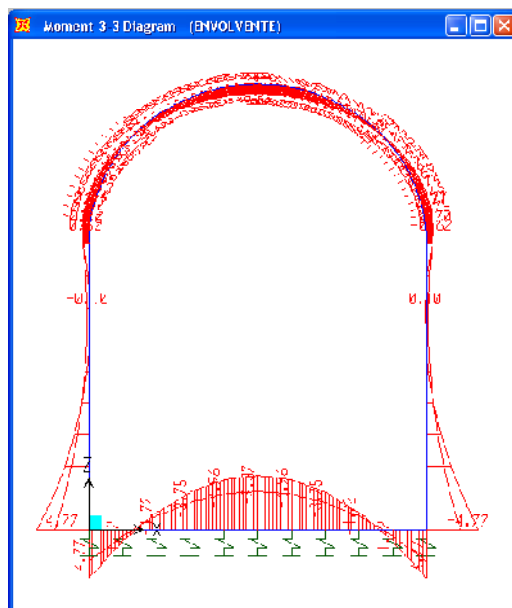
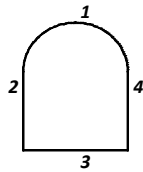



HOJA DE CALCULO

Código:
Revisión:
Página: de
Especialidad: Estructuras

Proyecto: Estudio Definitivo de la Carretera: Camaná - Desvio Quilca - Matarani - Ilo - Tacna; Desvio Quilca - Matarani
Descripción del Trabajo: Diseño de Alcantarillas Tipo Marco 1.00 x 1.00

DESARROLLO

REFERENCIA

4.20 Análisis por corte

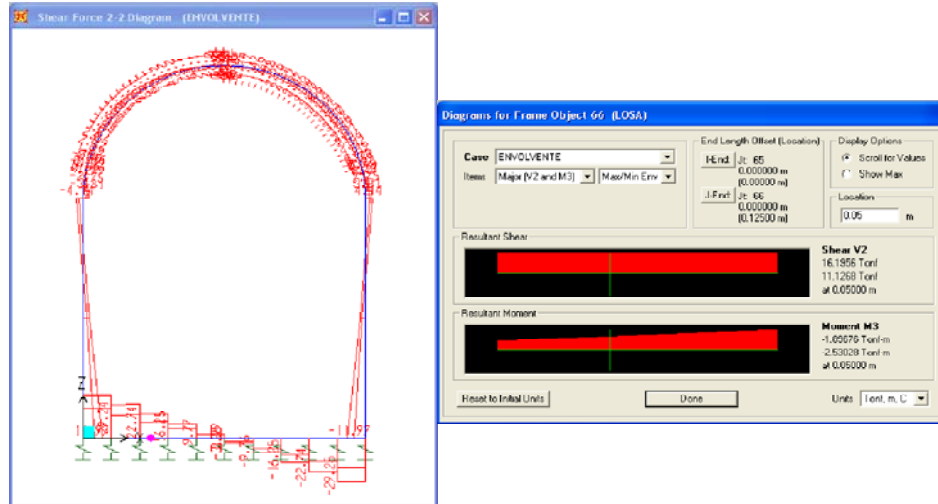

MOMENTOS DE DISEÑO

Barra 1 →	M- =	0.770	ton-m	M+ =	0.920	ton-m
Barra 2 →	M- =	4.770	ton-m	M+ =	0.100	ton-m
Barra 3 →	M- =	5.370	ton-m	M+ =	4.770	ton-m

5.00 DISEÑO DE MARCO

5.10 Por flexion

b=	100	cm.	f'c=	245	kg/cm ²
d=	20	cm.	d=	20	cm (paredes)

✓ Refuerzo Calculado de los Momentos de Diseño

Barra	As - (cm ²)	Varillas φ (")	@ (cm)	Usar S (cm)	As + (cm ²)	Varillas φ (")	@ (cm)	Usar S (cm)
1	1.029	3/8	69.01	25.00	1.231	3/8	57.69	25.00
		1/2	125.38	25.00		1/2	104.81	25.00
		5/8	194.39	25.00		5/8	162.50	25.00
2	6.591	3/8	10.77	10.00	0.133	3/8	534.17	25.00
		1/2	19.57	17.50		1/2	970.53	25.00
		5/8	30.35	25.00		5/8	1504.70	25.00
3	7.459	3/8	9.52	7.50	6.591	3/8	10.77	10.00
		1/2	17.29	15.00		1/2	19.57	17.50
		5/8	26.81	25.00		5/8	30.35	25.00



HOJA DE CALCULO

Código:
Revisión:
Página: de
Especialidad: Estructuras

Proyecto: Estudio Definitivo de la Carretera: Camaná - Desvio Quilca - Matarani - Ilo - Tacna; Desvio Quilca - Matarani
Descripción del Trabajo: Diseño de Alcantarillas Tipo Marco 1.00 x 1.00

DESARROLLO

REFERENCIA

✓ Mínimo Refuerzo

$$f_r = 2\sqrt{f'c} \rightarrow f_r = 31.30 \text{ kg/cm}^2$$

$$M_r = f_r \frac{bh^2}{6} \rightarrow M_r = 2.09 \text{ ton-m}$$

$$1.2 M_r = 2.50 \text{ ton-m}$$

$$\text{Mínimo} = \begin{cases} \text{As (1.2 Mcr)} = 3.394 \text{ cm}^2 \\ 4/3 \text{ As} \end{cases}$$

Barra	As.mín - (cm2)	Varillas ϕ (")	@ (cm)	Usar S (cm)	As.mín + (cm2)	Varillas ϕ (")	@ (cm)	Usar S (cm)
1	2.250	3/8	31.56	25.00	2.250	3/8	31.56	25.00
		1/2	57.33	25.00		1/2	57.33	25.00
		5/8	88.89	25.00		5/8	88.89	25.00
2	3.394	3/8	20.92	20.00	2.250	3/8	31.56	25.00
		1/2	38.01	25.00		1/2	57.33	25.00
		5/8	58.93	25.00		5/8	88.89	25.00
3	3.394	3/8	20.92	20.00	3.394	3/8	20.92	20.00
		1/2	38.01	25.00		1/2	38.01	25.00
		5/8	58.93	25.00		5/8	58.93	25.00

✓ Diseño Acero de Refuerzo

$$\text{MÁX} = (\text{As}, \text{As}_{\text{mín}})$$

Barra	As - (cm2)	Varillas ϕ (")	@ (cm)	Usar S (cm)	As + (cm2)	Varillas ϕ (")	@ (cm)	Usar S (cm)
1	2.250	3/8	31.56	25.00	2.250	3/8	31.56	25.00
		1/2	57.33	25.00		1/2	57.33	25.00
		5/8	88.89	25.00		5/8	88.89	25.00
	∴ Utilizar	1/2	@	25.00	∴ Utilizar	1/2	@	25.00
2	6.591	3/8	10.77	10.00	2.250	3/8	31.56	25.00
		1/2	19.57	17.50		1/2	57.33	25.00
		5/8	30.35	25.00		5/8	88.89	25.00
	∴ Utilizar	1/2	@	17.50	∴ Utilizar	1/2	@	25.00
3	7.459	3/8	9.52	7.50	6.591	3/8	10.77	10.00
		1/2	17.29	15.00		1/2	19.57	17.50
		5/8	26.81	25.00		5/8	30.35	25.00
	∴ Utilizar	5/8	@	25.00	∴ Utilizar	1/2	@	17.50

5.20 Por corte

b= 100 cm
dmax= 35 cm
d consid= 20 cm

d critica= 0.48 (+ .15 chafan)
d'= 0.78

Vmax= 16.20 Ton del programa (SAP 2000)
Vud= 16195.00 Kg (Cortante de Diseño)

Vuc= 16564.57 Kg

∴ Vuc > Vud → OK!!!



HOJA DE CALCULO

Código:
Revisión:
Página: de
Especialidad: Estructuras

Proyecto: Estudio Definitivo de la Carretera: Camaná - Desvio Quilca - Matarani - Ilo - Tacna; Desvio Quilca - Matarani
Descripción del Trabajo: Diseño de Alcantarillas Tipo Marco 1.00 x 1.00

DESARROLLO

REFERENCIA

6.00 DISEÑO DE VIGA SARDINEL

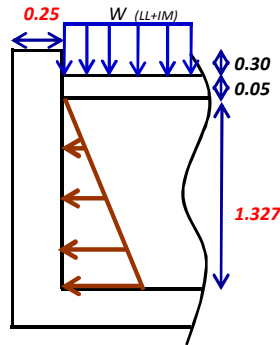

$f'_c = 245 \text{ Kg/cm}^2$
 $d = 20 \text{ cm}$
 $E_{DW} = 0.037 \text{ ton/m}$
 $E_H = 1.189 \text{ ton/m}$
 $E_{LL+IM} = 0.123 \text{ ton/m}$
 $\rightarrow V_u = 2.052 \text{ ton/m}$
 $V_c = 14.932 \text{ ton/m} > V_u \text{ OK!!!}$
 $M_{DW} = 0.024 \text{ ton-m/m}$
 $M_{EH} = 0.526 \text{ ton-m/m}$
 $M_{LL+IM} = 0.081 \text{ ton-m/m}$

$\rightarrow \mu_u = 0.967 \text{ ton/m}$
 $A_s = 1.295 \text{ cm}^2/\text{m}$

$\rightarrow \text{Usar } \phi \text{ } 1/2 \text{ "}$
 $\text{@ } 300 \text{ mm}$

7.00 PRESION TRANSMITIDA

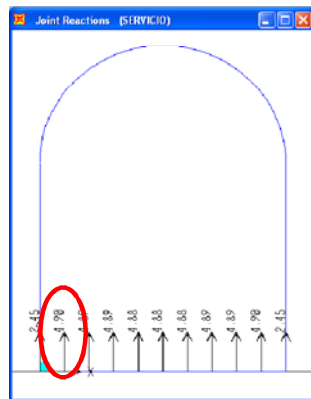
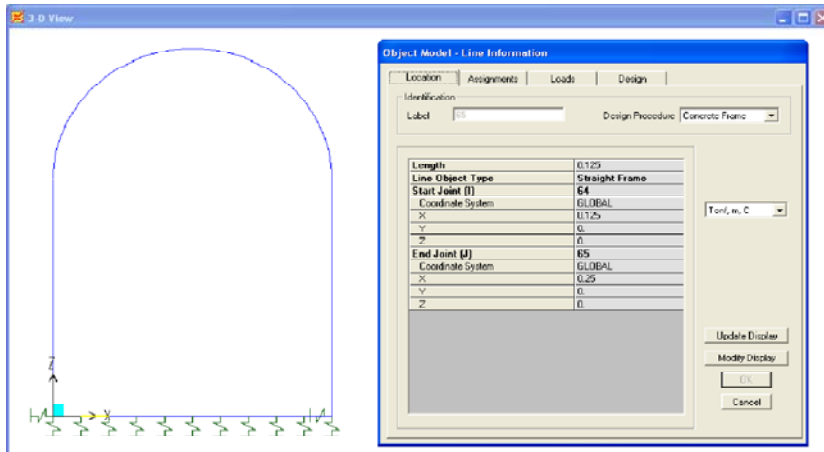

$P = 4.900 \text{ ton}$
 $AREA = 0.125 \text{ m}^2$

$$\text{Carga Transmitida} = \frac{\text{Fuerza}}{\text{Area}}$$

Carga Transmitida = 3.92 Kg/cm2



HOJA DE CALCULO

Código:
Revisión:
Página: de
Especialidad: Estructuras

Proyecto: Estudio Definitivo de la Carretera: Camaná - Desvio Quilca - Matarani - Ilo - Tacna; Desvio Quilca - Matarani
Descripción del Trabajo: Diseño de Alcantarillas Tipo Marco 1.00 x 1.00

DESARROLLO

REFERENCIA

ALAS

Altura máxima (m) = 2.50
Altura mínima (m) = 0.85

t(m) = 0.25

✓ E = 1.86 ton/m ME = 1.547 ton-m/m
Mu = 2.32 ton-m/m
b = 100.00 cm f'c = 245.00 Kg/cm2
d = 19.00 cm → As = 3.31 cm2

✓ **Mínimo Refuerzo**

$$As_{min} = \min \left[\frac{4}{3} As, As(1.2Mr) \right]$$

✓ **Calculo de Mr**

$$f_r = 2\sqrt{f'c}$$

$$M_r = fr \frac{bh^2}{6}$$

→ fr = 31.30 kg/cm2
Mr = 3.95 ton-m
1.2 Mr = 4.73 ton-m

→ As (1.2Mr) = 6.92 cm2
4/3 As = 4.42 cm2

As.min = 4.42 cm2

→ **Acero de Diseño = 4.42 cm2**

→ 1/2 " @ 275 mm

