



HOJA DE CALCULO

Código:
Revisión:
Página: de
Especialidad: Estructuras

Proyecto: Estudio Definitivo de la Carretera: Camaná - Desvio Quilca - Matarani - Ilo - Tacna; Desvio Quilca - Matarani
Descripción del Trabajo: Diseño de Alcantarillas Tipo Marco 1.50 x 1.50

DESARROLLO

REFERENCIA

ALCANTARILLA TIPO MARCO 1.50 x 1.50 - PROG. 49+905.42

1.00 DATOS

A = 1.500 m
B = 1.500 m
t = 0.300 m
t1 = 0.250 m
h = 10.89 m
S/C = HL93 → P = 7.256 ton
e = 0.050 asfalto
f'c = 245 kg/cm²
pe rell. = 1.800 ton/m³
Ko = 0.450 coef. Emp. Tierra reposo
Ks = 1000 Coeficiente de Balasto

2.00 GEOMETRIA

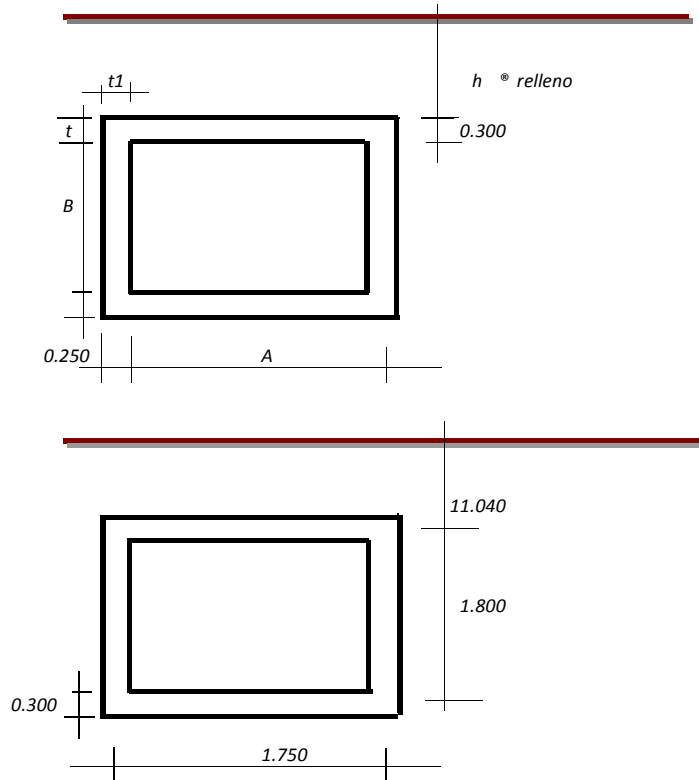



HOJA DE CALCULO

Código:
Revisión:
Página: de
Especialidad: Estructuras

Proyecto: Estudio Definitivo de la Carretera: Camaná - Desvio Quilca - Matarani - Ilo - Tacna; Desvio Quilca - Matarani
Descripción del Trabajo: Diseño de Alcantarillas Tipo Marco 1.50 x 1.50

DESARROLLO

REFERENCIA

3.00 METRADO DE CARGAS

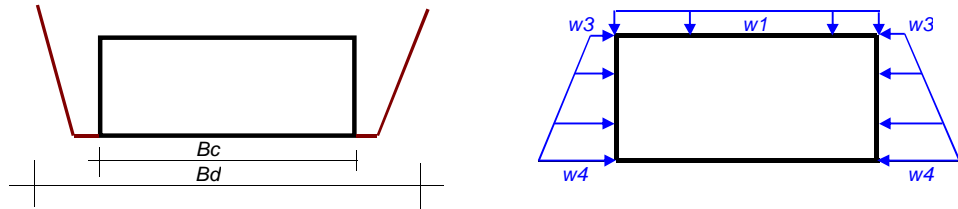

Bc= 2.000 m
H= 10.890 m

$$C_d = \frac{1 - e^{-2K_{\mu'} \frac{H}{B_d}}}{2K_{\mu'}}$$

Fe = 1.150

$$Fe = 1 + 0.20 \frac{H}{B_c}$$

$$w_2 = F_t \gamma_s H$$

w1 = 0.110 ton/m
w2 = 22.542 ton/m
w3 = 8.942 ton/m
w4 = 10.400 ton/m

Peso asfalto (DW)
Peso relleno (EV)
Empuje relleno (EH)

Impacto(I) = 1.000
w(LL+IM) = 0.157 ton/m

$$I = 1 + 0.33 \times (1 - 0.41H)$$

Sobrecarga (LL+IM)

4.00 ANALISIS

Resistencia I = 1.25 DC + 1.50 DW + 1.35 EV + (1.35 - 0.90) EH + 1.75 LL+IM
Servicio I = 1.00 DC + 1.00 DW + 1.00 EV + 1.00 EH + 1.00 LL+IM

4.10 Análisis por flexión

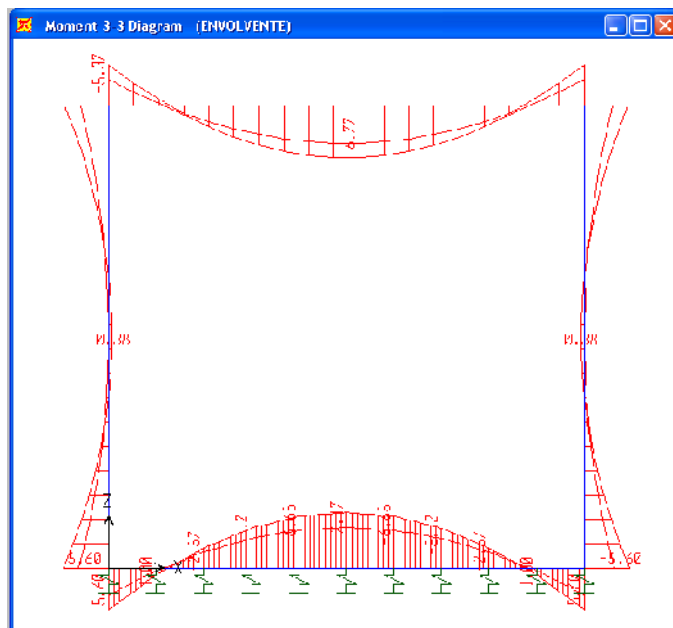
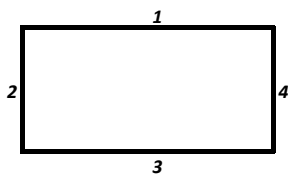



HOJA DE CALCULO

Código:
Revisión:
Página: de
Especialidad: Estructuras

Proyecto: Estudio Definitivo de la Carretera: Camaná - Desvío Quilca - Matarani - Ilo - Tacna; Desvío Quilca - Matarani
Descripción del Trabajo: Diseño de Alcantarillas Tipo Marco 1.50 x 1.50

DESARROLLO

REFERENCIA

4.20 Análisis por corte

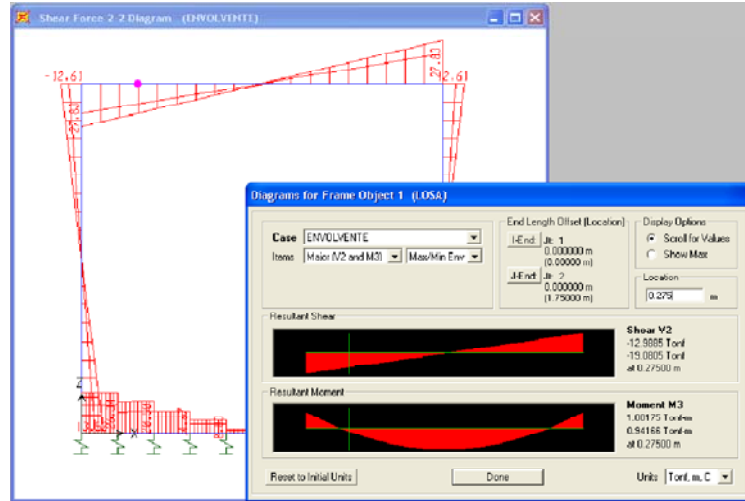

MOMENTOS DE DISEÑO

Barra 1 → M- = 5.370 ton-m M+ = 6.770 ton-m
Barra 2 → M- = 5.600 ton-m M+ = 0.380 ton-m
Barra 3 → M- = 7.170 ton-m M+ = 5.600 ton-m

5.00 DISEÑO DE MARCO

5.10 Por flexion

b= 100 cm. f'c= 245 kg/cm2
d= 25 cm. d= 20 cm (paredes)

✓ Refuerzo Calculado de los Momentos de Diseño

Barra	As - (cm2)	Varillas φ (")	@ (cm)	Usar S (cm)	As + (cm2)	Varillas φ (")	@ (cm)	Usar S (cm)
1	5.868	3/8	12.10	10.00	7.455	3/8	9.52	7.50
		1/2	21.98	20.00		1/2	17.30	15.00
		5/8	34.09	25.00		5/8	26.83	25.00
2	7.795	3/8	9.11	7.50	0.506	3/8	140.26	25.00
		1/2	16.55	15.00		1/2	254.84	25.00
		5/8	25.66	25.00		5/8	395.10	25.00
3	7.913	3/8	8.97	7.50	6.127	3/8	11.59	10.00
		1/2	16.30	15.00		1/2	21.06	20.00
		5/8	25.28	25.00		5/8	32.64	25.00



HOJA DE CALCULO

Código:
Revisión:
Página: de
Especialidad: Estructuras

Proyecto: Estudio Definitivo de la Carretera: Camaná - Desvio Quilca - Matarani - Ilo - Tacna; Desvio Quilca - Matarani
Descripción del Trabajo: Diseño de Alcantarillas Tipo Marco 1.50 x 1.50

DESARROLLO

REFERENCIA

✓ Mínimo Refuerzo

$$f_r = 2\sqrt{f'c}$$

$$M_r = f_r \frac{bh^2}{6}$$

Mínimo = $\left\{ \begin{array}{l} As (1.2 M_{cr}) = \\ 4/3 As \end{array} \right.$

$$\rightarrow \begin{array}{ll} f_r = & 31.30 \text{ kg/cm}^2 \\ M_r = & 3.26 \text{ ton-m} \\ 1.2 M_r = & 3.91 \text{ ton-m} \end{array}$$

$$As (1.2 M_{cr}) = 4.242 \text{ cm}^2$$

Barra	As.mín - (cm2)	Varillas ϕ (")	@ (cm)	Usar S (cm)	As.mín + (cm2)	Varillas ϕ (")	@ (cm)	Usar S (cm)
1	4.242	3/8	16.74	15.00	4.242	3/8	16.74	15.00
		1/2	30.41	25.00		1/2	30.41	25.00
		5/8	47.14	25.00		5/8	47.14	25.00
2	4.242	3/8	16.74	15.00	2.700	3/8	26.30	25.00
		1/2	30.41	25.00		1/2	47.78	25.00
		5/8	47.14	25.00		5/8	74.07	25.00
3	4.242	3/8	16.74	15.00	4.242	3/8	16.74	15.00
		1/2	30.41	25.00		1/2	30.41	25.00
		5/8	47.14	25.00		5/8	47.14	25.00

✓ Diseño Acero de Refuerzo

$$MÁX = (As, As_{mín})$$

Barra	As - (cm2)	Varillas ϕ (")	@ (cm)	Usar S (cm)	As + (cm2)	Varillas ϕ (")	@ (cm)	Usar S (cm)
1	5.868	3/8	12.10	10.00	7.455	3/8	9.52	7.50
		1/2	21.98	20.00		1/2	17.30	15.00
		5/8	34.09	25.00		5/8	26.83	25.00
		∴ Utilizar	1/2	@		20.00	∴ Utilizar	5/8
2	7.795	3/8	9.11	7.50	2.700	3/8	26.30	25.00
		1/2	16.55	15.00		1/2	47.78	25.00
		5/8	25.66	25.00		5/8	74.07	25.00
		∴ Utilizar	5/8	@		25.00	∴ Utilizar	1/2
3	7.913	3/8	8.97	7.50	6.127	3/8	11.59	10.00
		1/2	16.30	15.00		1/2	21.06	20.00
		5/8	25.28	25.00		5/8	32.64	25.00
		∴ Utilizar	5/8	@		25.00	∴ Utilizar	1/2

5.20 Por corte

b= 100 cm
dmax= 40 cm
d consid= 25 cm

d critica= 0.53 (+ .15 chafan)
d'= 1.23

Vmax= 19.08 Ton del programa (SAP 2000)
Vud= 19080.50 Kg (Cortante de Diseño)

Vuc= 21421.43 Kg

∴ Vuc > Vud → OK!!!



HOJA DE CALCULO

Código:
Revisión:
Página: de
Especialidad: Estructuras

Proyecto: Estudio Definitivo de la Carretera: Camaná - Desvio Quilca - Matarani - Ilo - Tacna; Desvio Quilca - Matarani
Descripción del Trabajo: Diseño de Alcantarillas Tipo Marco 1.50 x 1.50

DESARROLLO

REFERENCIA

6.00 DISEÑO DE VIGA SARDINEL

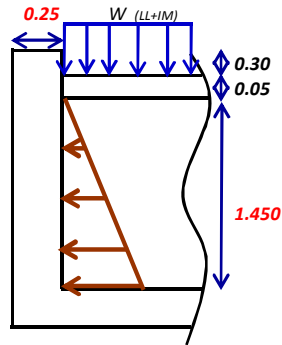

$f'_c = 245 \text{ Kg/cm}^2$
 $d = 20 \text{ cm}$
 $E_{DW} = 0.037 \text{ ton/m}$
 $E_H = 1.419 \text{ ton/m}$
 $E_{LL+IM} = 0.118 \text{ ton/m}$
 $\rightarrow V_u = 2.390 \text{ ton/m}$
 $V_c = 14.932 \text{ ton/m} > V_u \text{ OK!!!}$
 $M_{DW} = 0.027 \text{ ton-m/m}$
 $M_{EH} = 0.686 \text{ ton-m/m}$
 $M_{LL+IM} = 0.086 \text{ ton-m/m}$

$\rightarrow Mu = 1.219 \text{ ton/m}$
 $As = 1.634 \text{ cm}^2/\text{m}$

$\rightarrow \text{Usar } \phi \text{ } 1/2 \text{ "}$
 $\text{ @ } 300 \text{ mm}$

7.00 PRESION TRANSMITIDA

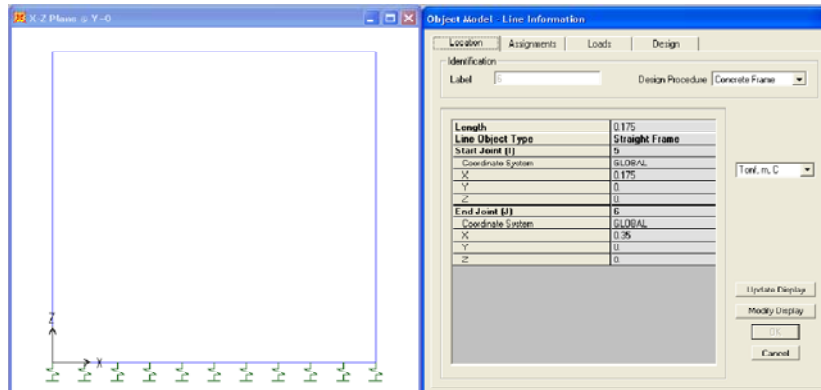

$P = 4.460 \text{ ton}$
 $AREA = 0.175 \text{ m}^2$

$$\text{Carga Transmitida} = \frac{\text{Fuerza}}{\text{Area}}$$

Carga Transmitida = 2.55 Kg/cm2

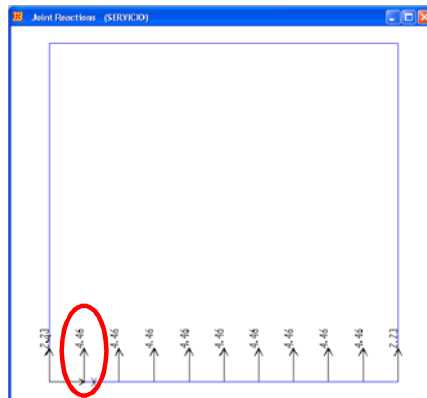



HOJA DE CALCULO

Código:
Revisión:
Página: de
Especialidad: Estructuras

Proyecto: Estudio Definitivo de la Carretera: Camaná - Desvio Quilca - Matarani - Ilo - Tacna; Desvio Quilca - Matarani
Descripción del Trabajo: Diseño de Alcantarillas Tipo Marco 1.50 x 1.50

DESARROLLO

REFERENCIA

ALAS

Altura máxima (m) = 3.30
Altura mínima (m) = 1.50

t(m) = 0.25

✓ E = 3.23 ton/m ME = 3.558 ton-m/m
Mu = 5.34 ton-m/m
b = 100.00 cm f'c = 245.00 Kg/cm2
d = 19.00 cm → As = 7.84 cm2

✓ **Mínimo Refuerzo**

$$As_{min} = \min \left[\frac{4}{3} As, As(1.2Mr) \right]$$

✓ **Calculo de Mr**

$$f_r = 2\sqrt{f'c}$$

$$M_r = fr \frac{bh^2}{6}$$

→ fr = 31.30 kg/cm2
Mr = 3.95 ton-m
1.2 Mr = 4.73 ton-m

→ As (1.2Mr) = 6.92 cm2
4/3 As = 10.46 cm2

As.min = 6.92 cm2

→ **Acero de Diseño = 7.84 cm2**

→ 5/8 " @ 250 mm

