

48+200
1) Perfilado Lado Izq = 4.62
2) Perfilado Lado Der = 5.24

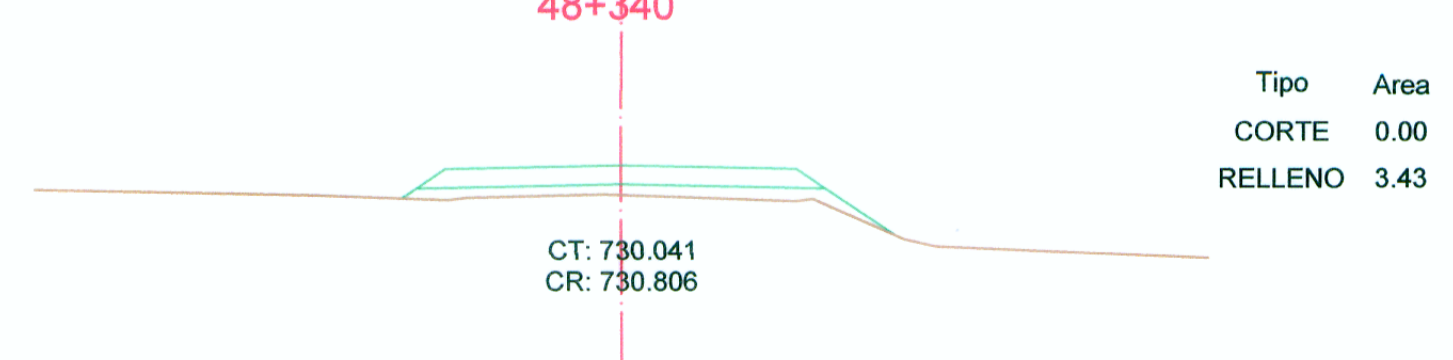
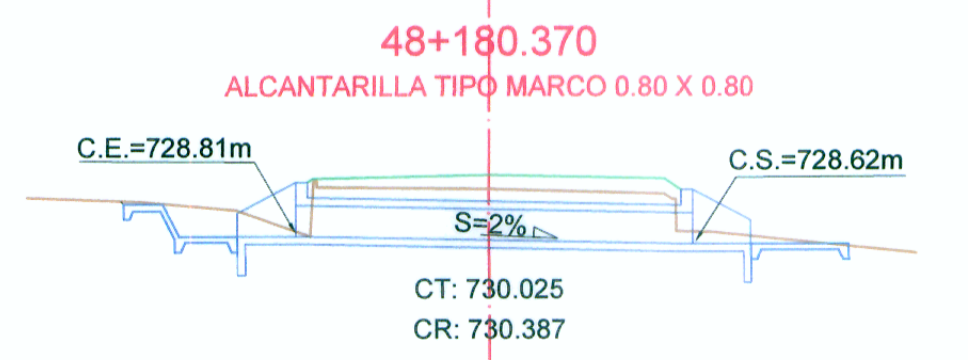
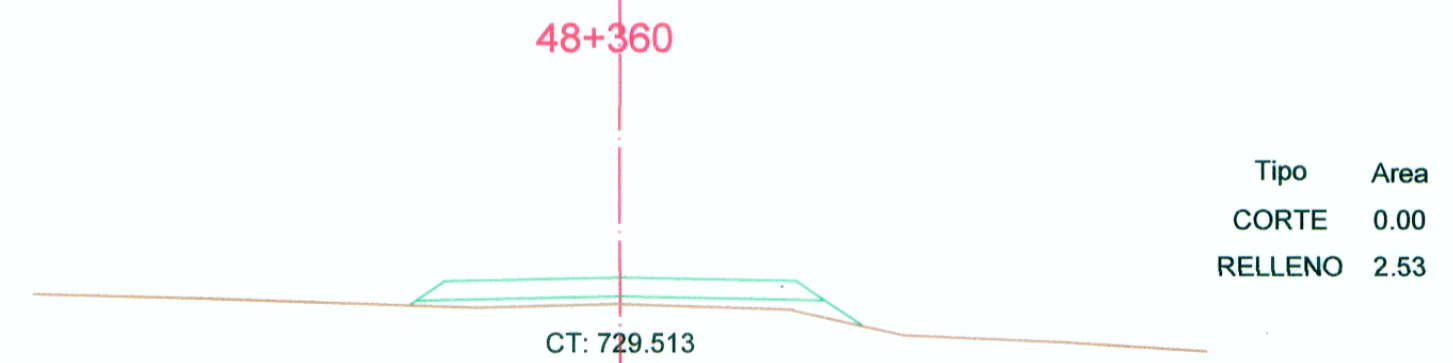
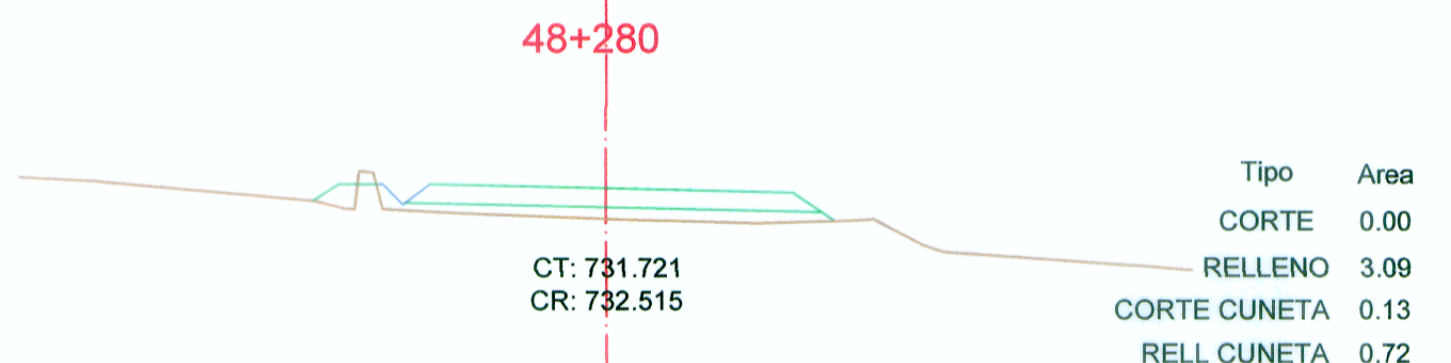
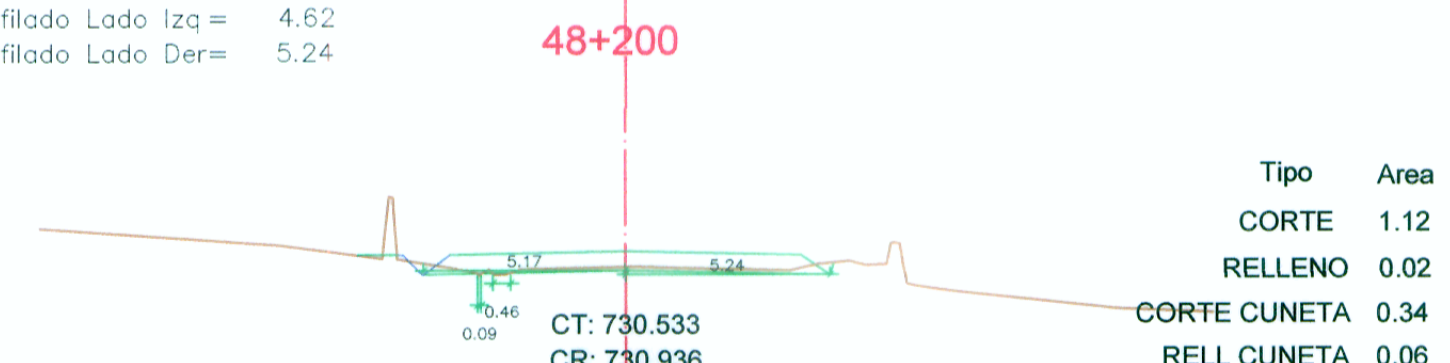

Elaborado por el Proyecto de Rehabilitación y Mejoramiento de la Carretera Huará - Sayan - Churín Km. 48+180.37 al 48+420
Ing. María Mayorca
Reg. C.I.P. 9434