

Item	Progresiva		Longitud (ml)	
	Inicio	Final	Derecho	Izquierda
1	17+150.00	17+700.00	550.00	
2	17+150.00	17+700.00		550.00
3	18+800.00	19+320.00		520.00
4	19+100.00	19+160.00	60.00	
5	20+680.00	20+960.00		280.00
6	20+800.00	20+900.00	100.00	
8	27+840.00	28+250.00		410.00
9	27+840.00	28+250.00	410.00	
10	30+600.00	31+300.00	700.00	
11	30+700.00	31+300.00		600.00
12	32+280.00	33+540.00		1,260.00
13	32+550.00	34+060.00	1,510.00	
14	34+660.00	35+640.00		980.00
15	34+550.00	35+700.00	1,150.00	
16	35+780.00	35+880.00		100.00
17	36+300.00	36+500.00	200.00	
18	36+360.00	36+550.00		190.00
19	36+690.00	38+330.00	1,640.00	
20	36+690.00	38+650.00		1,960.00
21	38+780.00	38+900.00	120.00	
22	38+930.00	39+125.00		195.00
23	39+380.00	40+050.00	670.00	
24	39+125.00	40+050.00		925.00
25	40+190.00	42+140.00	1,950.00	
26	40+190.00	42+140.00		1,950.00
27	42+300.00	42+844.00		544.00

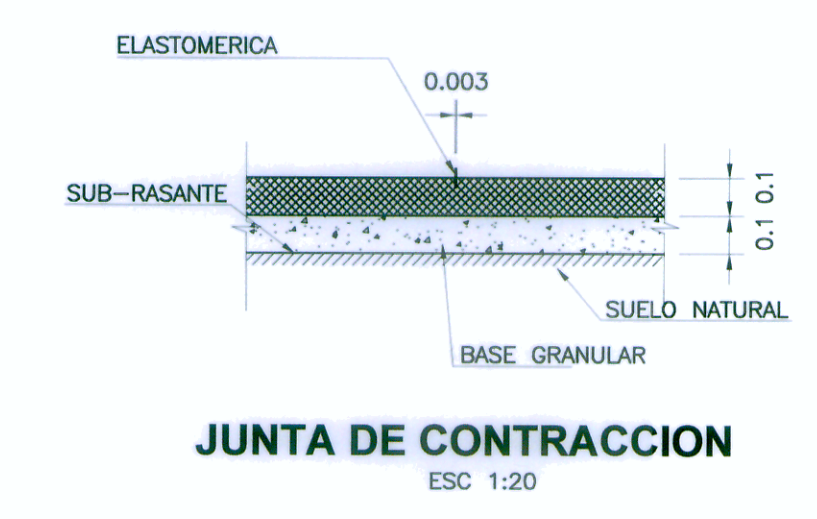
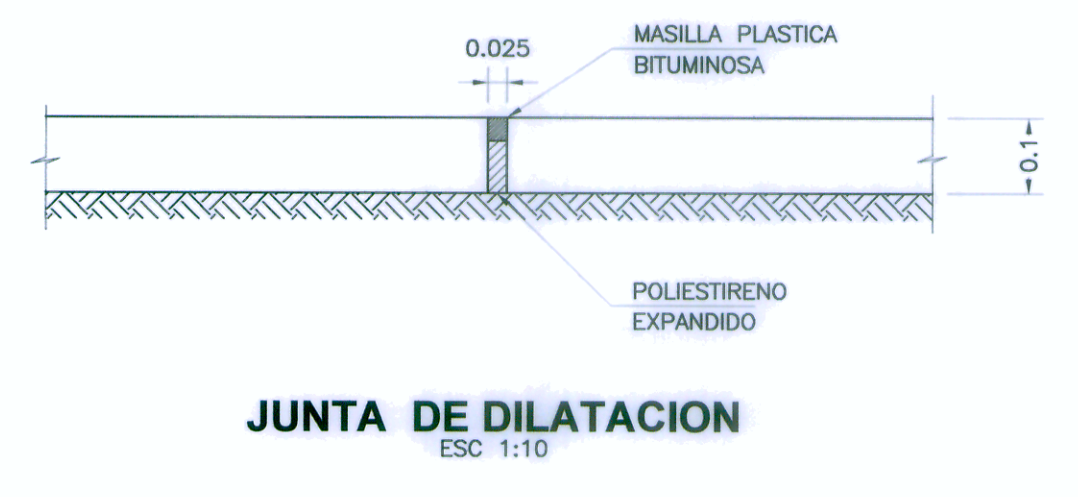
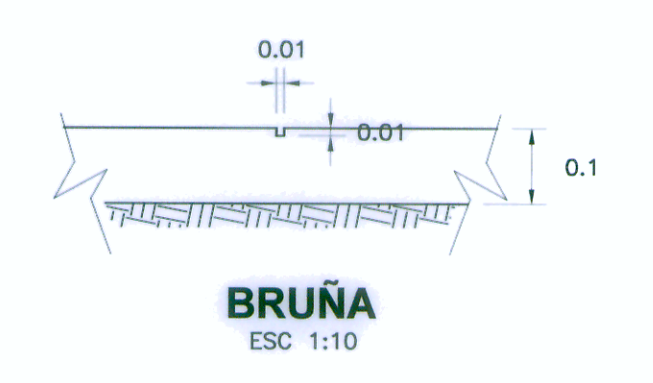
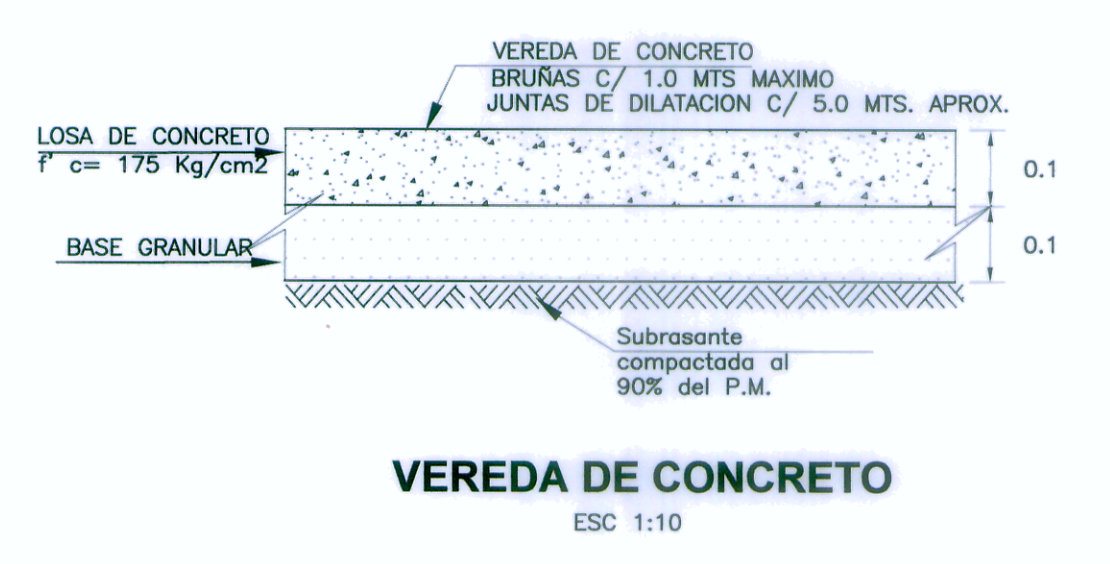
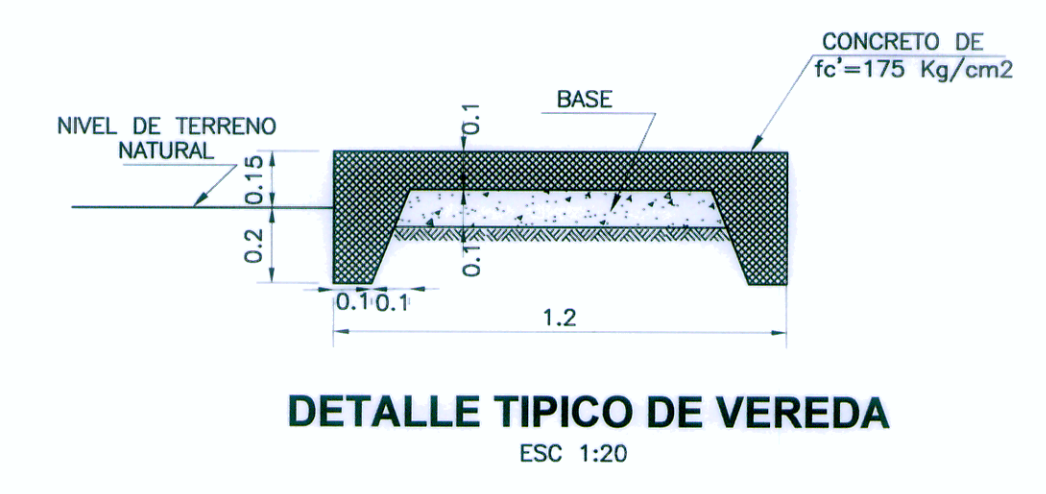

Ministerio de Transportes y Comunicaciones
 Viceministerio de Transportes
Proviás Nacional

PROYECTISTA:
CESEL INGENIEROS
 CERTIFICADO EN: ISO 9001, ISO 14001, OHSAS 18001

Diseñó: **ING. C. SALCEDO D.**
 CIP 72062
 Dibujó: **A. C. M.**
 Verificó: **ING. O. TORRES R.**
 CIP 15227
 Presentó: **ING. O. TORRES R.**
 CIP 15227

Aprobó:

REVISIONES		
Nº	FECHA	DESCRIPCION
0	19/04/11	EMITIDO PARA CONSTRUCCION

ESTUDIO DEFINITIVO DE REHABILITACIÓN Y MEJORAMIENTO DE LA CARRETERA CAÑETE - LUNAHUANÁ
 CONTRATO N° 051 - 2010 - MTC/20

VEREDAS-DETALLES
 UBICACION: **INDICADA**

ESCALA: **INDICADA**
 FECHA: **ABRIL 2011**
 PLANO N°: **051-10-OA-102**
 REV. 0

Ing. Manuel O. Torres Rosas
 Jefe de Estudio
 CIP 15227
 Ing. Elisa Carrera Cabrera
 Especialista en Estructuras y Obras de Arte
 CIP 11378

NOTA :
 1.- LA ESCALA INDICADA ES PARA EL FORMATO A-1, PARA A-3 CONSIDERAR EL DOBLE