

72+040

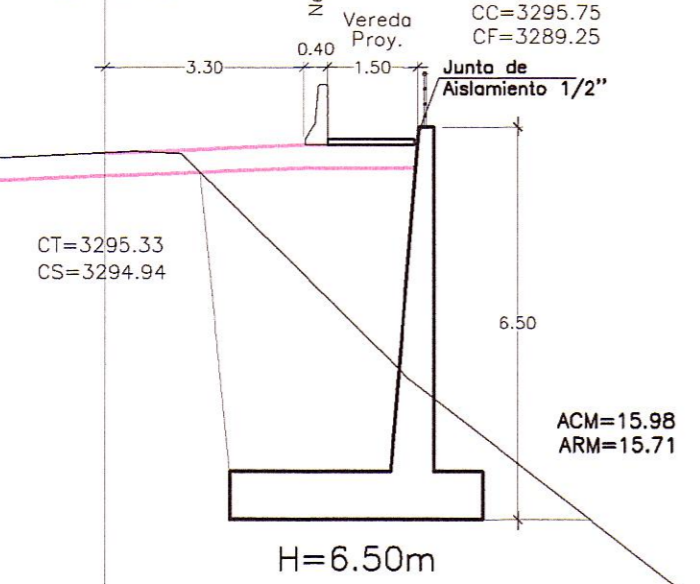

72+035

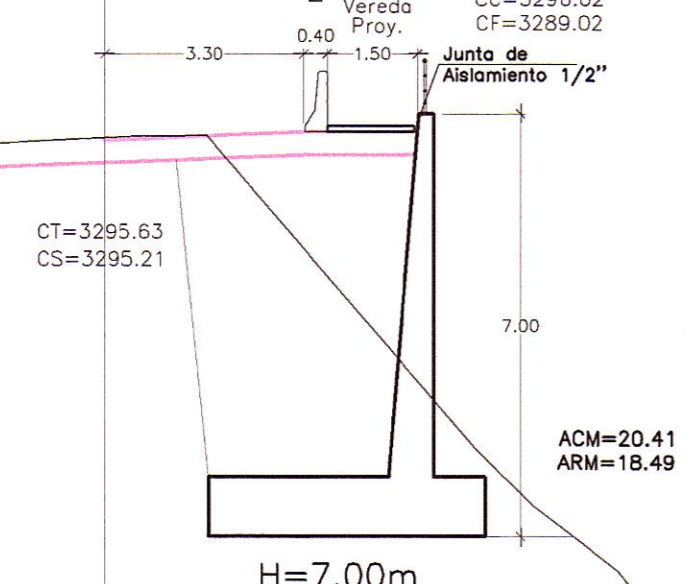

72+030

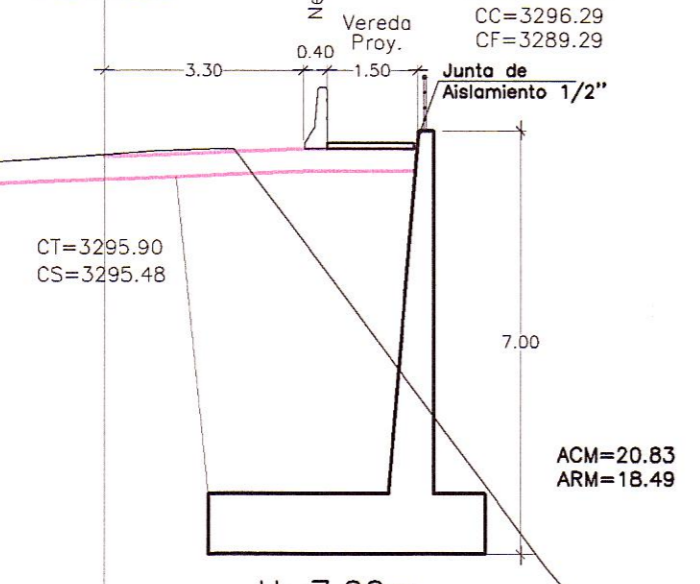

72+025

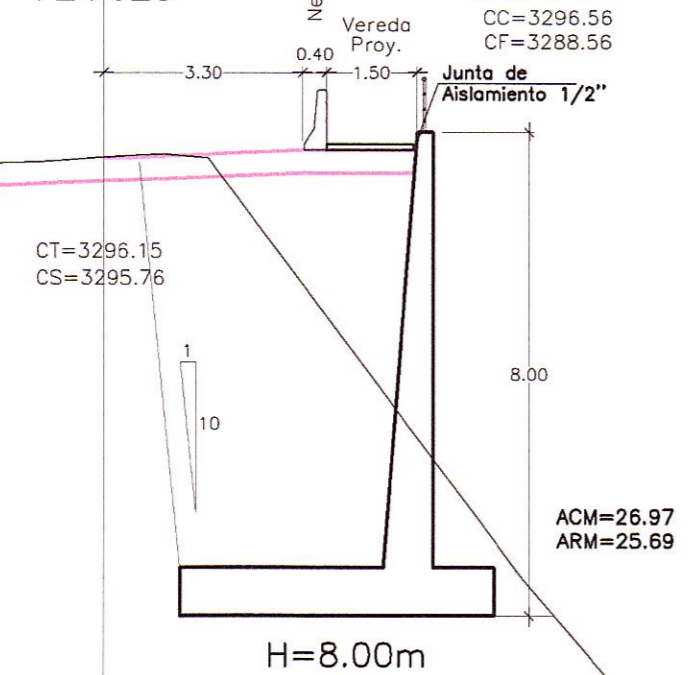

72+065

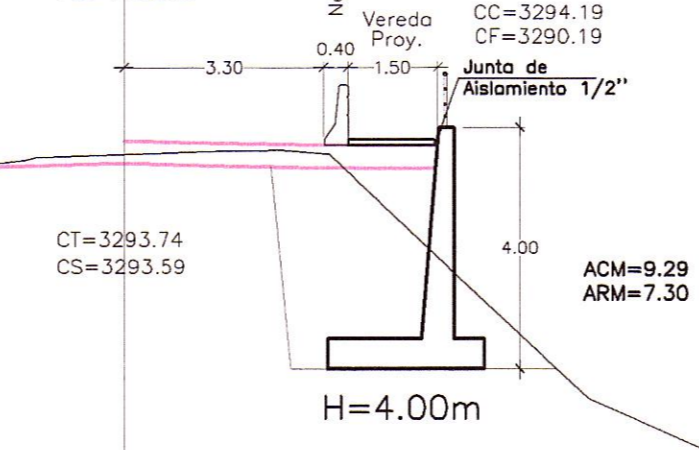

72+060

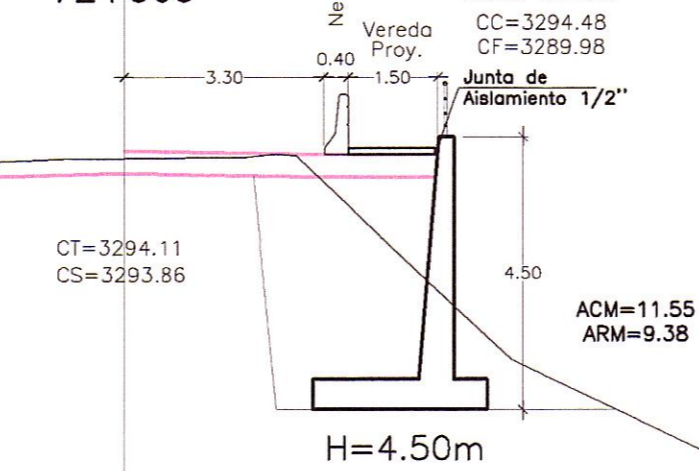

72+055

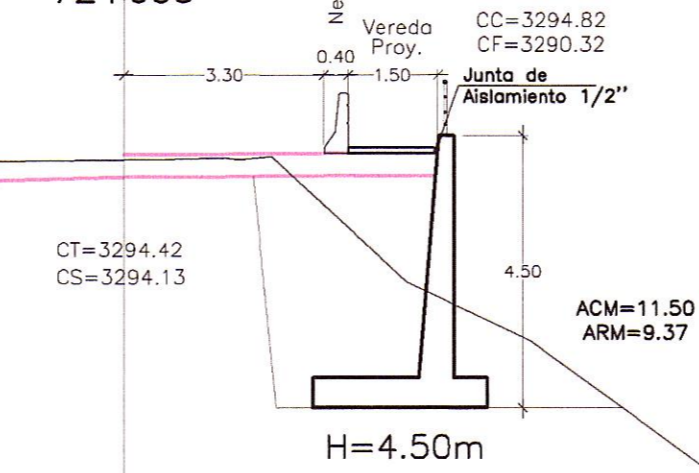

72+050

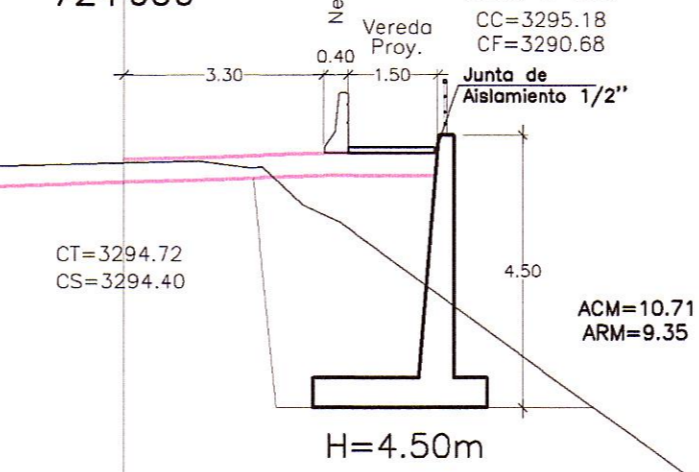

72+045

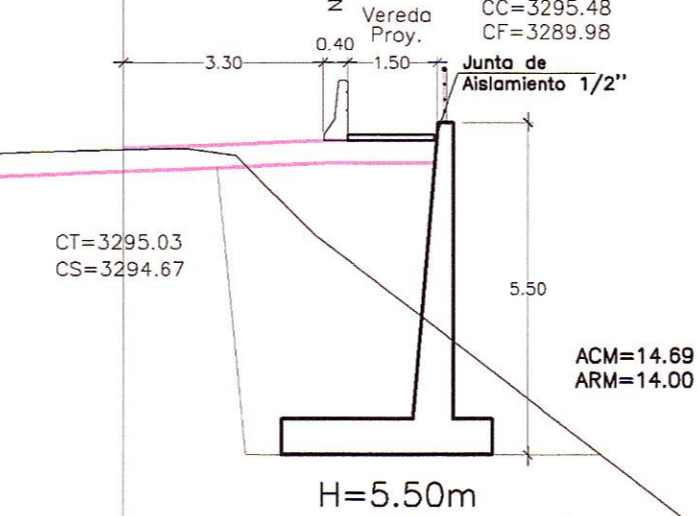

72+100

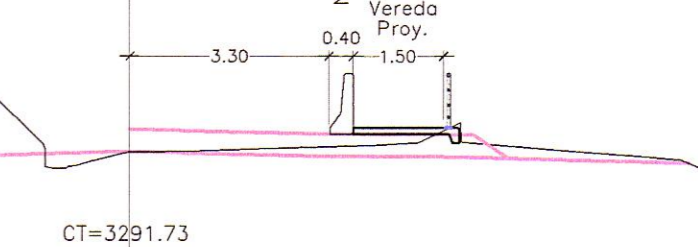

72+095

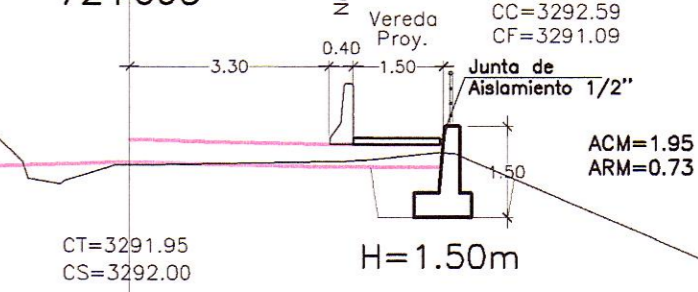

72+090

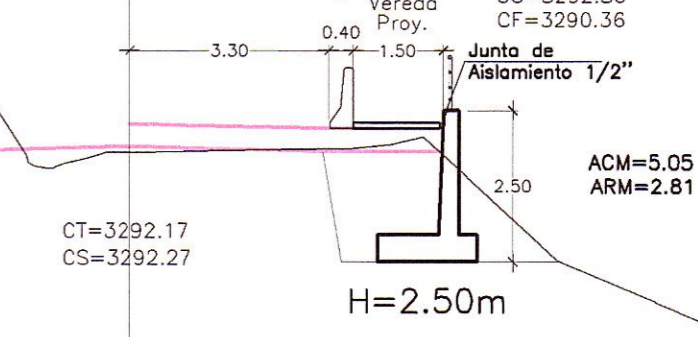

72+085

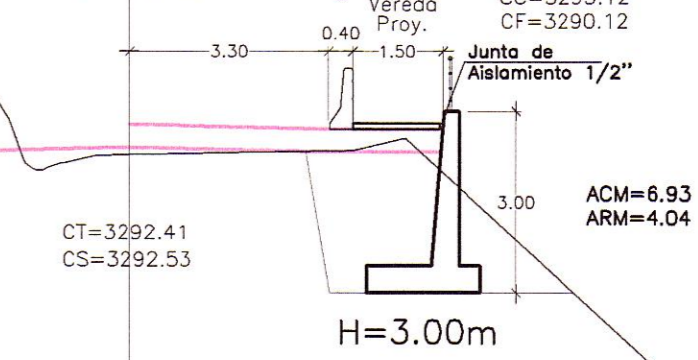

72+080

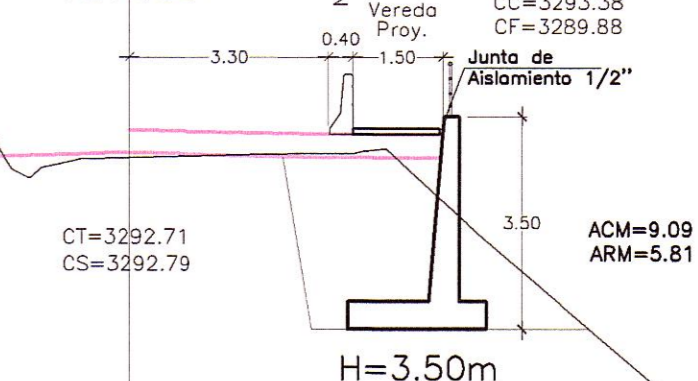

72+075

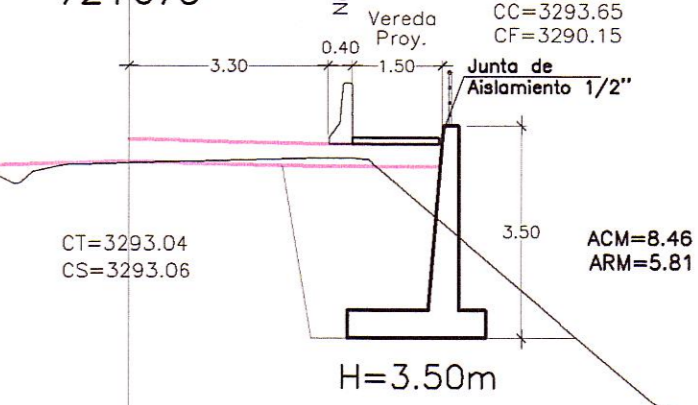

72+070

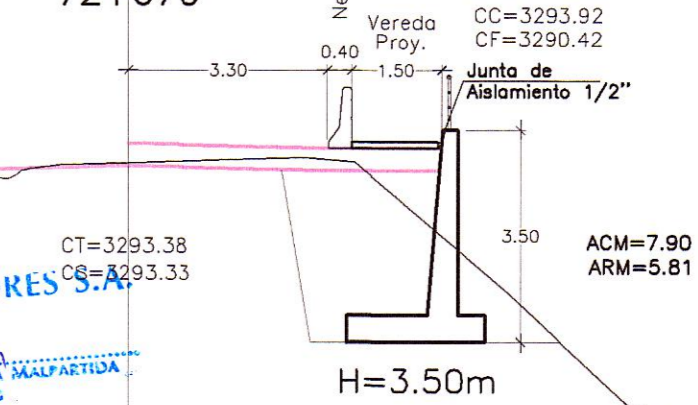

SECCIONES TRANSVERSALES

ESC. : 1/125

HOB CONSULTORES S.A.

HOB CONSULTORES S.A.



**LEYENDA**

CERCO DE CONCRETO
CERCO DE ADOBE
CERCO DE PIEDRA
CERCO DE ALAMBRE
CERCO DE MADERA
LIMITE DE PROPIEDAD

**LEYENDA**

CT= COTA TERRENO
CS= COTA SUBRASANTE
CC= COTA CORDON MURO
CF= COTA FONDO MURO

Logo of the Ministry of Transport and Communications of Peru, and the National Provinces.

Logo of Compañía de Minas Buenaventura.

Logo of HOB CONSULTORES S.A. with contact information: Calle Aguada Blanca N° 102 - Lima 33 - Peru. Telephone: 715-8111, Fax: 715-8324. Email: hob@hobperu.com

Elaborado por: ING. CESAR GUEVARA  
 Especialista: ING. AERLIS DE LA ROSA TORO  
 Revisado:  
 Proceso y Ploteo: GER. ESTUDIOS-HOB

Aprobación:

**REVISIONES**

N°	FECHA	DESCRIPCION

ESTUDIO DEFINITIVO DE LA REHABILITACION Y MEJORAMIENTO CARRETERA: HUANCAMELICA - LIRCAY TRAMO: 1+550(Av. Los Chancas)-LIRCAY CONTRATO N° 7341-2012

**MURO CONCRETO ARMADO**  
 KM 71+870 - KM 72+095

FECHA: SEPTIEMBRE 2013  
 ESCALA FORMATO A1: 1/2000  
 ESCALA FORMATO A3: 1/4000  
**7341-12-0A-31g**